An Introduction to Steam Generators

Course No: M05-019

Credit: 5 PDH

J. Paul Guyer, P.E., R.A., Fellow ASCE, Fellow AEI



Continuing Education and Development, Inc.
22 Stonewall Court
Woodcliff Lake, NJ 07677

P: (877) 322-5800
info@cedengineering.com

An Introduction to Steam Generators



J. Paul Guyer, P.E., R.A.

Paul Guyer is a registered civil engineer, mechanical engineer, fire protection engineer and architect with 35 years experience designing buildings and related infrastructure. For an additional 9 years he was a principal staff advisor to the California Legislature on capital outlay and infrastructure issues. He is a graduate of Stanford University and has held numerous national, state and local offices with the American Society of Civil Engineers, Architectural Engineering Institute and National Society of Professional Engineers.

CONTENTS

1. INTRODUCTION
2. BOILER DESIGN
3. BOILER CONSTRUCTION OPTIONS
4. AVAILABLE FUELS
5. COAL ASH CHARACTERISTICS
6. COMBUSTION TECHNOLOGY SELECTION
7. PULVERIZERS (MILLS)
8. COAL BURNER IGNITORS
9. BURNERS AND NO_x CONTROL
10. PRIMARY AIR
11. STOKERS
12. STOKER FEED
13. FLY ASH REINJECTION FOR COAL FIRING
14. OVERFIRE AIR
15. ATMOSPHERIC CIRCULATING FLUIDIZED BED (ACFB)
 BOILER COMPONENTS
16. BOILER COMPONENTS
17. BOILER WATER CIRCULATION AND CHEMICAL TREATMENT
18. BOILER STACKS
19. ADJUSTABLE SPEED DRIVES

(This publication is adapted from the Unified Facilities of the United States government which are in the public domain, have been authorized for unlimited distribution, and are not copyrighted.)

1. INTRODUCTION.

1.1 GENERAL. This publication addresses the design requirements for gas, oil, coal, and waste fuel fired steam generating, water-tube boilers and components with steam capacities between 20,000 and 250,000 pph and maximum pressures of 450 pounds per inch gauge (psig)/saturated and 400 psig/700 degrees F superheated.

1.2 NEW COMBUSTION TECHNOLOGIES. The only major development in combustion technology in the past seventy years has been fluidized bed combustion.

1.2.1 HISTORY. Earlier fluidized bed technologies included the bubbling bed boiler. Bubbling bed boiler efficiency is similar to that of a stoker boiler (80 to 82 percent). Atmospheric circulating fluidized bed (ACFB) boiler efficiency is comparable to pulverized coal boiler efficiency (86 to 88 percent). Bubbling bed boilers are not included in this discussion not only because they are less fuel efficient, but also because they are inferior to ACFB units in the areas of sorbent utilization, emissions reductions and fuel flexibility.

1.2.2 ADVANTAGES. Fluidized bed boilers have gained acceptance in the industrial and utility sectors by providing an economical means of using a wide range of fuels while meeting emissions requirements without installing flue gas desulfurization systems, such as wet and dry type scrubbers.

1.2.3 EMISSION REDUCTIONS. Sulfur capture is accomplished by injecting a sorbent, such as limestone or dolomite into the furnace along with coal and other solid fuels. Storage and handling of limestone must be included. Optimum sulfur capture and reduced thermal NO_x (nitrogen oxide) emissions are achieved by maintaining a combustion temperature at approximately 1550 degree F which is lower than other coal firing technologies. Sulfur is removed as calcium sulfate in the baghouse and either land-filled or sold.

1.2.4 UNIQUE COMPONENTS. Atmospheric fluidized bed (ACFB) boilers, in addition to having components which are common to other combustion technologies (superheater, airheater, steam coil air preheater, economizer, sootblowers, etc.), they have unique components. The following list of unique ACFB boiler components is described in more detail in individual sections later in this publication: lower combustor, upper combustor and transition zone, solids separator, solids reinjection device, and external heat exchanger (optional).

2. BOILER DESIGN.

2.1 DESIGN. Boilers will be designed and constructed in accordance with Section 1 of the American Society of Mechanical Engineers (ASME) Boiler and Pressure Vessel Code.

2.2 TYPE. The boilers are to be natural circulation and two-drum design. Coal fired boilers are balanced draft and gas/oil fired boilers are forced draft.

3. BOILER CONSTRUCTION OPTIONS.

3.1 CONSTRUCTION TYPES. The specific type of boiler construction will depend on the boiler size, type of firing and life cycle costs. Three boiler construction types are available: shop assembled package units, field assembled modular units and field erected units.

3.2 PACKAGE UNITS. Package units are completely assembled before leaving the boiler manufacturer's factory. For this reason, the quality of workmanship is generally better and the field installation costs are considerably lower than for the modular and field erected units. Package units covered by this publication are limited to stoker fire boilers with steam capacities of approximately 50,000 pph and below, and gas and/or oil fired units of approximately 200,000 pph and below.

3.3 MODULAR UNITS. Modular units are too large for complete shop assembly. Some of the components, such as the boiler furnace, superheater, boiler tube bank and economizer and air heater are assembled in the manufacturer's shop prior to shipment for final erection at the field site. Modular units should be subject to better quality control due to manufacturing plant conditions. Since component assembly has taken place in the manufacturer's shop, the field man-hour erection time will be reduced. Modular units are limited to stoker fired boilers ranging in steam capacity from approximately 50,000 to 150,000 pph.

3.4 FIELD ERECTED UNITS. Field erected boilers have numerous components, such as the steam drum, the lower (mud) drum, furnace wall panels, superheater sections, generating tube banks, economizer and air heater plus flue gas and air duct sections which are assembled at the job site. Therefore, they take longer to install than either a package or a modular type unit. Field erected units are available from about 40,000 to 250,000 pph and, if required, much larger. Field erected stoker fired boilers are available in this size range, and pulverized coal fired units may be specified for boilers with capacities of 100,000 pph and above. Field erected atmospheric circulating

fluidized bed boilers (ACFB) are 80,000 pph or larger. Gas and oil boilers are field erected for capacities of 200,000 pph or larger. Field erected units are the only boilers available for any of these technologies above 200,000 pph.

4. AVAILABLE FUELS.

4.1 NATURAL GAS. Natural gas is the cleanest burning of the widely used commercially available fuels. It contains virtually no ash which reduces design, building and operating costs. This also eliminates the need for particulate collection equipment such as baghouses or electrostatic precipitators. Thorough mixing with combustion air allows low excess air firing. The high hydrogen content of natural gas compared to the oil or coal causes more water vapor to be formed in the flue gas. This water takes heat away from the combustion process, making less heat available for steam generation which lowers the boiler efficiency.

4.2 NATURAL GAS ANALYSIS. Two types of analyses of natural gas are commonly used. Proximate analysis provides the percentage content by volume of methane, ethane, carbon dioxide and nitrogen. Ultimate analysis provides the percentage content by weight of hydrogen, carbon, nitrogen and oxygen. Table 1 gives natural gas analyses from selected United States fields.

4.3 FUEL OIL. Compared to coal, fuel oils are relatively easy to handle and burn. Ash disposal and emissions are negligible. When properly atomized oil characteristics are similar to natural gas. Even though oil contains little ash, other constituents such as sulfur, sodium and vanadium present fired problems. These concerns include emission of pollutants, external deposits and corrosion.

4.4 FUEL OIL ANALYSIS. Historically petroleum refineries have produced five different grades of fuel oil. Fuel oils are graded according to gravity and viscosity as defined by ASTM standard specifications with No. 1 being the lightest and No. 6 being the heaviest. Table 2 lists typical analyses of the various grades.

4.5 COAL TYPES. For the purpose of boiler design, domestic U.S. coals are divided into four basic classifications: lignite, subbituminous, bituminous, and anthracite.

Anthracite, however, requires special furnace and burner designs due to its low volatile content and is not normally used in the U.S. for boiler fuel. Note the following illustrations in Figures 1 and 2 below. In general, these coal classifications refer to the ratio of fixed carbon to volatile matter and moisture contained in the coal, which increases with the action of pressure, heat, and other agents over time as coal matures. The changes in this ratio over the stages of coal information are illustrated in Figure 3. Volatile matter consists of hydrocarbons and other compounds which are released in gaseous form when coal is heated. The amount present in a particular coal is related to the coal's heating value and the rate at which it burns. The volatile matter to fixed carbon ratio greatly affects boiler design, since the furnace dimensions must allow the correct retention time to properly burn the fuel.

	<i>Pittsburg</i>	<i>So. Cal.</i>	<i>Birmingham</i>	<i>Kansas City</i>	<i>Los Angeles</i>
<i>Proximate, % by Volume</i>					
Methane CH ₄	83.40	84.00	90.00	84.10	77.50
Ethane C ₂ H ₆	15.80	14.80	5.00	6.70	16.00
Carbon D.CO ₂	—	0.70	—	0.80	6.50
Nitrogen N ₂	0.80	0.50	5.00	8.40	—
Total	100.00	100.00	100.00	100.00	100.00
<i>Ultimate % by Weight</i>					
Hydrogen H ₂	25.53	23.30	22.68	20.85	20.35
Carbon C	75.25	74.72	69.26	64.84	69.28
Nitrogen N ₂	1.22	0.76	8.06	12.90	—
Oxygen O ₂	—	1.22	—	1.41	10.37
Total	100.00	100.00	100.00	100.00	100.00
Sp Gr (Air= 1.0)	0.610	0.636	0.600	0.630	0.697
HHV Btu/ft ³ *	1,129	1,116	1,000	974	1,073
Btu/lb	23,170	22,904	21,800	20,160	20,090
Fuel lb/10,000 Btu	0.432	0.437	0.459	0.496	0.498
Theoretical Air lb/10,000 Btu	7.18	7.18	7.50	7.19	7.18
Total Moisture lb/10,000 Btu	0.915	0.917	0.971	0.933	0.911

*At 60 degree F and 30 in. Hg

Table 1
Analyses of natural gas from selected United States fields

<i>Weight, %</i>	<i>No. 1</i>	<i>No. 2</i>	<i>No. 4</i>	<i>No. 5</i>	<i>No. 6</i>
Sulfur	0.01-0.5	0.05-1.0	0.2-2.0	0.5-3.0	0.7-3.5
Hydrogen	13.3-14.1	11.8-13.9	(10.6-13.0)*	(10.5-12.0)*	(9.5-12.0)*
Carbon	85.9-6.7	86.1-88.2	(86.5-89.2)*	(86.5-89.2)*	(86.5-90.2)*
Nitrogen	0-0.1	0-0.1	—	—	—
Oxygen	—	—	—	—	—
Ash	—	—	0-0.10	0-0.10	0.01-0.50
<i>Gravity</i>					
Deg API	40-44	28-40	15-30	14-22	7-22
Specific	0.825-0.806	0.887-0.825	0.966-0.876	0.972-0.922	1.022-0.922
Lb per gal	6.87-6.71	7.39-6.87	8.04-7.30	8.10-7.68	8.51-7.68
Pour Pt,F	0 to-50	0 to -40	-10 to +50	-10 to +80	+15 to +85
<i>Viscosity</i>					
Centistokes, 100 F	1.4-2.2	1.9-3.0	10.5-65	65-200	260-750
SSU @100 F	—	32-40	60-300	—	—
SFS @ 122 F	—	—	—	20-40	45-300
Water & Sediment, Vol %	—	0-0.1	0-1.0	0.05-1.0	0.05-2.0
Heating Value Btu/lb, gross (Calculated)	19,670-19,860	19,170-19,750	18,280-19,400	18,100-19,020	17,410-18,990
*Estimated					

Table 2
Range of analyses of fuel oils

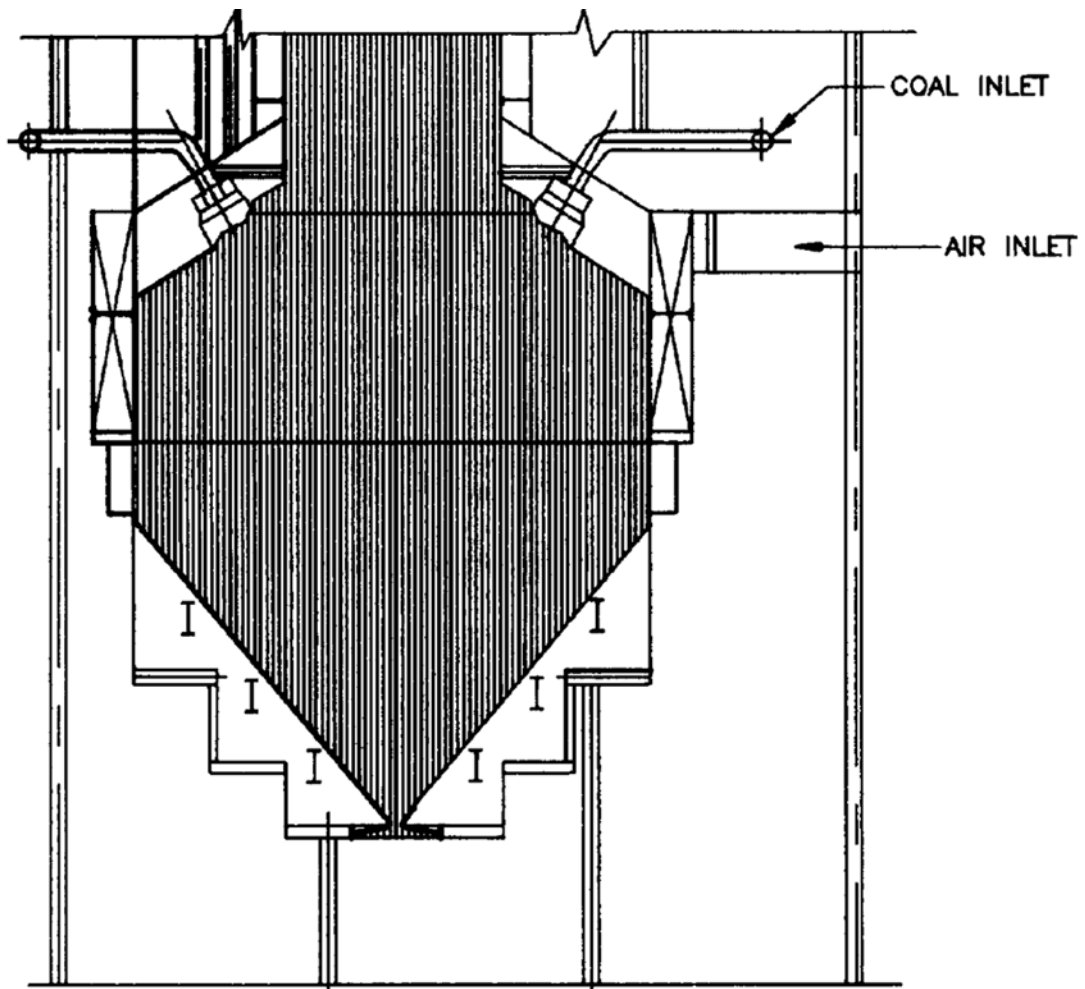

Figure 1

Typical furnace design for pulverized anthracite and low volatile
or petroleum coke type solid fuels

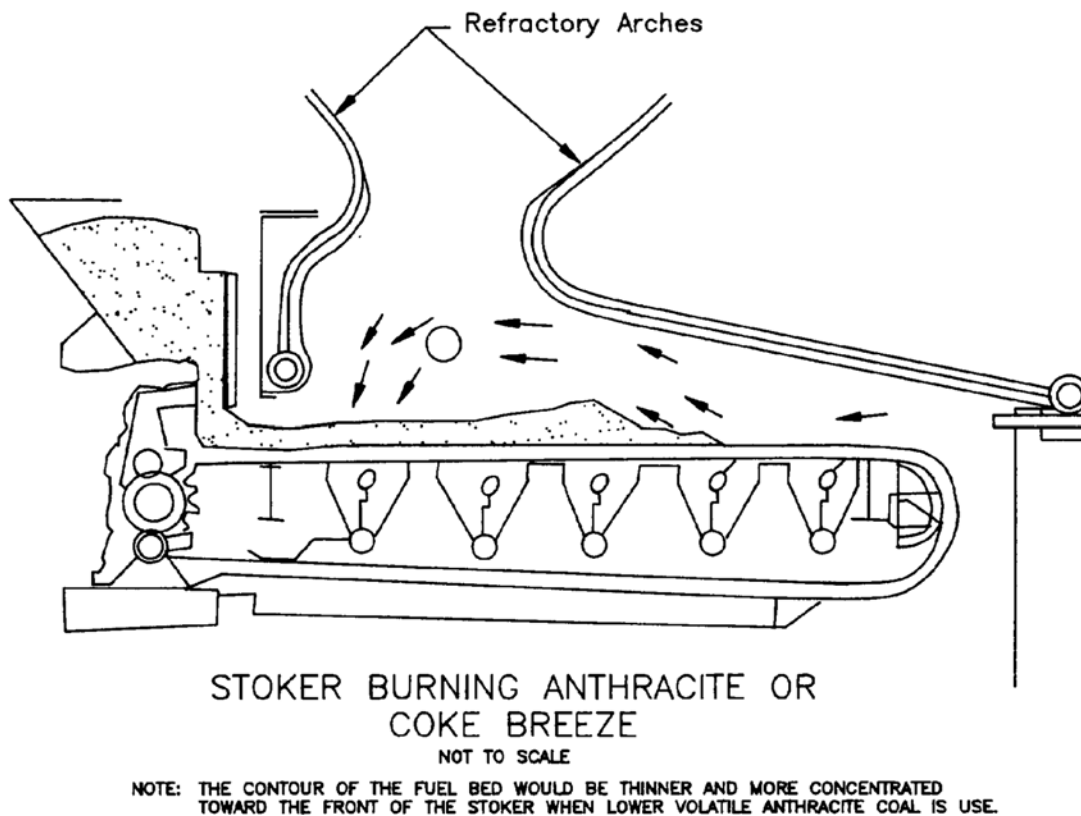

Figure 2

Typical stoker arch arrangement for anthracite coal

4.6 COAL ANALYSIS. Two analyses of coal are commonly used to determine the classification constituents of coal: proximate analysis and ultimate analysis. Proximate analysis provides the percentage content by weight of fixed carbon, volatile matter, moisture, and ash, and the heating value in Btu per pound. These classifications are shown in Table 3. Ultimate analysis provides the percentage content by weight of carbon, hydrogen, nitrogen, oxygen, and sulfur. These data are used to determine air requirements and the weight of combustion by-products, both of which are used to determine boiler fan sizes. Table 4 lists coal and ash analysis together, ash fusion temperatures and other data needed by boiler manufacturers for the design and guarantee of boiler performance.

4.7 ALTERNATE ACFB BOILER FUELS. ACFB systems when properly designed can burn a wide variety of materials that contain carbon. Many can be utilized by themselves, while others are limited to a certain percentage of total heat input as part of a mixture with another fuel. Fuels with sulfur are burned in combination with a calcium rich material such as dolomite or limestone. Sulfur is removed as calcium sulfate in the baghouse and either landfilled or sold. If sulfur capture is not required, then another manufacturer recommended inert material such as sand may be used. ACFB fuel flexibility includes the following list of potential fuels:

- (1) Anthracite coal
- (2) Anthracite culm
- (3) Bark and woodwaste
- (4) Bituminous coal
- (5) Bituminous gob
- (6) Gasifier char
- (7) Industrial sludges, wastes, residues
- (8) Lignite
- (9) Municipal refuse
- (10) Oil
- (11) Oil shale
- (12) Paper products waste
- (13) Peat
- (14) Petroleum coke
- (15) Phenolic resins
- (16) Plastics
- (17) Sewage sludge
- (18) Subbituminous coal
- (19) Textile waste
- (20) Shredded tires

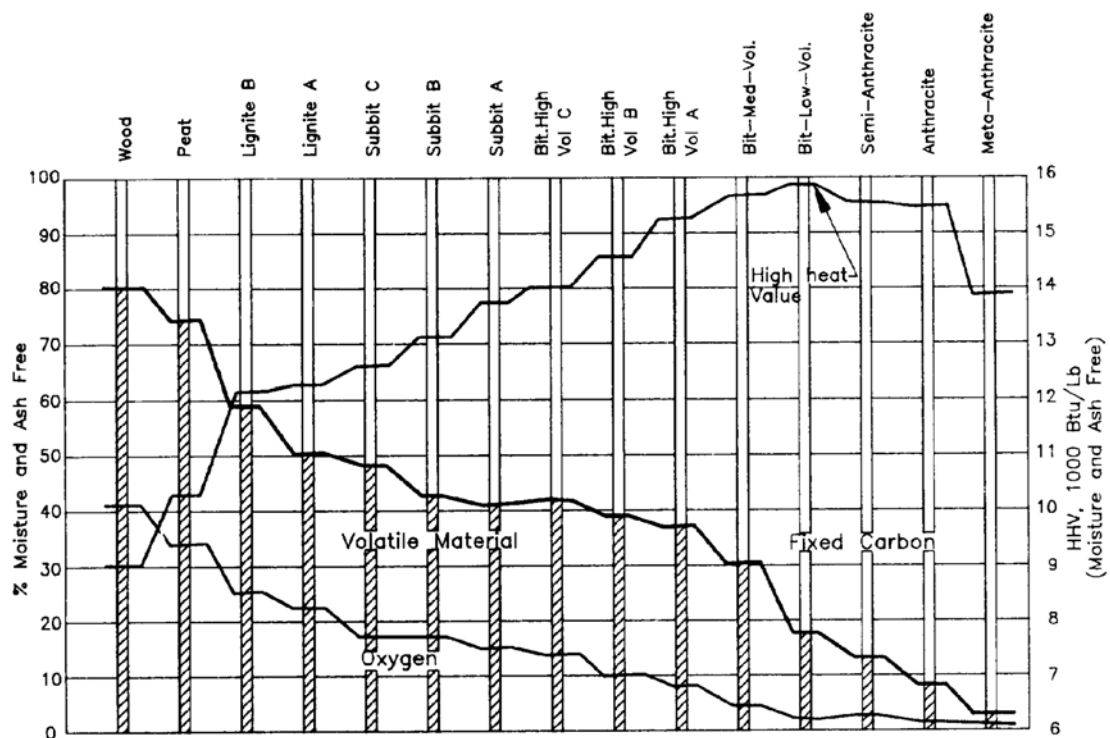

Figure 3
Progressive stages of coal formation

State	Rank	Btu/lb	% Proximate Analysis				% Ultimate Analysis					
			H ₂ O	VM	FC	Ash	H ₂ O	C	H ₂	S	O ₂	N ₂
AL	F	14,210	5.5	30.8	60.9	2.8	5.5	80.3	4.9	0.6	4.2	1.7
AR	C	13,700	2.1	9.8	78.8	9.3	2.1	80.3	3.4	1.7	1.7	1.5
AR	D	13,700	3.4	16.2	71.8	8.6	3.4	79.6	3.9	1.0	1.8	1.7
CO	B	13,720	2.5	5.7	83.8	8.0	2.5	83.9	2.9	0.7	0.7	1.3
CO	F	13,210	1.4	32.6	54.3	11.7	1.4	73.4	5.1	0.6	6.5	1.3
CO	1	10,130	19.6	30.5	45.9	4.0	19.6	58.8	3.8	0.3	12.2	1.3
IA	H	10,720	14.1	35.6	39.3	11.0	14.1	58.5	4.0	4.3	7.2	0.9
IL	G	12,130	8.0	33.0	50.6	8.4	8.0	68.7	4.5	1.2	7.6	1.6
IL	H	11,480	12.1	40.2	39.1	8.6	12.1	62.8	4.6	4.3	6.6	1.0
IN	H	11,420	12.4	36.6	42.3	8.7	12.4	63.4	4.3	2.3	7.6	1.3
KS	F	12,670	7.4	31.8	52.4	8.4	7.4	70.7	4.6	2.6	5.0	1.3
KY	F	14,290	3.1	35.0	58.9	3.0	3.1	79.2	5.4	0.6	7.2	1.5
KY	G	12,080	7.5	37.7	45.3	9.5	7.5	66.9	4.8	3.5	6.4	1.4
MD	D	13,870	3.2	18.2	70.4	8.2	3.2	79.0	4.1	1.0	2.9	1.6
MI	H	11,860	12.4	35.0	47.0	5.6	12.4	65.8	4.5	2.9	7.4	1.4
MO	F	12,990	5.4	32.1	53.5	9.0	5.4	71.6	4.8	3.6	4.2	1.4
MO	G	11,300	10.5	32.0	44.6	12.9	10.5	63.4	4.2	2.5	5.2	1.3
ND	J	7,210	34.8	28.2	30.8	6.2	34.8	42.4	2.8	0.7	12.4	0.7

Table 3
Analysis of typical U.S. coals (as mined)

State	Rank	Btu/lb	% Proximate Analysis				% Ultimate Analysis					
			H ₂ O	VM	FC	Ash	H ₂ O	C	H ₂	S	O ₂	N ₂
NM	B	13,340	2.9	5.5	82.7	8.9	2.9	82.3	2.6	0.8	1.3	1.2
NM	F	12,650	2.0	33.5	50.6	13.9	2.0	70.6	4.8	1.3	6.2	1.2
OH	F	12,990	4.9	36.6	51.2	7.3	4.9	71.9	4.9	2.6	7.0	1.4
OH	G	12,160	8.2	36.1	48.7	7.0	8.2	68.4	4.7	1.2	9.1	1.4
OK	D	13,800	2.6	16.5	72.2	8.7	2.6	80.1	4.0	1.0	1.9	1.7
OK	F	13,630	2.1	35.0	57.0	5.9	2.1	76.7	4.9	0.5	7.9	2.0
PA*	B	11,950	5.4	3.8	77.1	13.7	5.4	76.1	1.8	0.6	1.8	0.6
PA**	B	13,540	2.3	3.1	87.7	6.9	2.3	86.7	1.9	0.5	0.9	0.8
PA***	B	12,820	4.9	3.7	82.2	9.2	4.9	81.6	1.8	0.5	1.3	0.7
PA	C	13,450	3.0	8.4	78.9	9.7	3.0	80.2	3.3	0.7	2.0	1.1
PA	E	14,310	3.3	20.5	70.0	6.2	3.3	80.7	4.5	1.8	2.4	1.1
PA	F	13,610	2.6	30.0	58.3	9.1	2.6	76.6	45.9	1.3	3.9	1.6
RI	A	9,313	13.3	2.5	65.3	18.9	13.3	64.2	0.4	0.3	2.7	0.2
TN	F	13,890	1.8	35.9	56.1	6.2	1.8	77.7	5.2	1.2	6.0	1.9
TX	F	12,230	4.0	48.9	34.9	12.2	4.0	65.5	5.9	2.0	9.1	1.3
TX	J	7,350	33.7	29.3	29.7	7.3	33.7	42.5	3.1	0.5	12.1	0.8
UT	F	12,990	4.3	37.2	51.8	6.7	43.0	72.2	5.1	1.1	9.0	1.6
VA	C	11,850	3.1	10.6	66.7	19.6	3.1	70.5	3.2	0.6	2.2	0.8
VA	E	14,030	3.1	21.8	67.9	7.2	3.1	80.1	4.7	1.0	2.4	1.5
VA	F	14,510	2.2	36.0	58.0	3.8	2.2	80.6	5.5	0.7	5.9	1.3
WA	F	12,610	4.3	37.7	47.1	10.9	4.3	68.9	5.4	0.5	8.5	1.5
WV	D	14,730	2.7	17.2	76.1	4.0	2.7	84.7	4.3	0.6	2.2	1.5
WV	F	14,350	2.4	33.0	60.0	4.6	2.4	80.8	5.1	0.7	4.8	1.6
WY	G	12,960	5.1	40.5	49.8	4.6	5.1	73.0	5.0	0.5	10.6	1.2
WY	I	9,420	23.2	33.3	39.7	3.8	23.2	54.6	3.8	0.4	13.2	1.0

*Orchard Bed. **Mammoth Bed. ***Holmes Bed.
RANK KEY: A-Meta-anthracite
B-Anthracite
C-Semianthracite
D-Low Volatile Bituminous
E-Medium Volatile Bituminous
F-High Volatile Bituminous A
G-High Volatile Bituminous B
H-High Volatile Bituminous C
I-Subbituminous
J-Lignite

Table 3 (continued)
Analysis of typical U.S. coals (as mined)

	<i>As Received (Raw)</i>		<i>Washed</i>	
	Typical	Range	Typical	Range
<i>Proximate Analysis</i>				
Moisture (%)	_____	_____ to _____	_____	_____ to _____
Ash (%)	_____	_____ to _____	_____	_____ to _____
Fixed Carbon (%)	_____	_____ to _____	_____	_____ to _____
Total	100.0		100.0	
Btu per pound (as received)	_____	_____ to _____	_____	_____ to _____
Btu per pound (dry)	_____	_____ to _____	_____	_____ to _____
Sulfur (%)	_____	_____ to _____	_____	_____ to _____
<i>Ultimate Analysis</i>				
Carbon (%)	_____	_____ to _____	_____	_____ to _____
Hydrogen (%)	_____	_____ to _____	_____	_____ to _____
Nitrogen (%)	_____	_____ to _____	_____	_____ to _____

Table 4

Typical coal and ash analysis information suitable for boiler design

	<i>As Received (Raw)</i>		<i>Washed</i>	
	Typical	Range	Typical	Range
Chlorine (%)	_____	_____ to _____	_____	_____ to _____
Sulfur (%)	_____	_____ to _____	_____	_____ to _____
Ash (%)	_____	_____ to _____	_____	_____ to _____
Oxygen (%)	_____	_____ to _____	_____	_____ to _____
Moisture (%)	_____	_____ to _____	_____	_____ to _____
<i>Mineral Analysis</i>				
Phos. Pentoxide, P ₂ O ₅	_____	_____ to _____	_____	_____ to _____
Silica, SiO ₂	_____	_____ to _____	_____	_____ to _____
Ferric Oxide, Fe ₂ O ₃	_____	_____ to _____	_____	_____ to _____
Alumina, Al ₂ O ₃	_____	_____ to _____	_____	_____ to _____
Titania, TiO ₂	_____	_____ to _____	_____	_____ to _____
Calcium Oxide, CaO	_____	_____ to _____	_____	_____ to _____
Magnesium Oxide, MgO	_____	_____ to _____	_____	_____ to _____
Sulfur Trioxide, SO ₃	_____	_____ to _____	_____	_____ to _____
Potassium Oxide, K ₂ O	_____	_____ to _____	_____	_____ to _____
Sodium Oxide, Na ₂ O	_____	_____ to _____	_____	_____ to _____
Undetermined	_____	_____ to _____	_____	_____ to _____
Total	100.0		100.0	
		<i>Reducing</i>	<i>Oxidizing</i>	
<i>Fusion Temperature of Ash, deg. F</i>				
Initial Deformation (IT)	_____	_____	_____	_____
Softening (H=W)	_____	_____	_____	_____
Hemispherical (H= 1/2W)	_____	_____	_____	_____
Fluid (FT)	_____	_____	_____	_____
Free Swelling Index	_____	_____	_____	_____
Viscosity T ₂₅₀ , deg. F	_____	_____ to _____	_____	_____ to _____
Silica Value	_____	_____ to _____	_____	_____ to _____
Base/Acid Ratio	_____	_____ to _____	_____	_____ to _____
<i>Sulfur Forms</i>				
Pyritic Sulfur (%)	_____	_____ to _____	_____	_____ to _____
Sulfate Sulfur (%)	_____	_____ to _____	_____	_____ to _____
Organic Sulfur (%)	_____	_____ to _____	_____	_____ to _____
<i>Water Soluble Alkalis</i>				
Water Soluble Na ₂ O	_____	_____ to _____	_____	_____ to _____
Water Soluble K ₂ O	_____	_____ to _____	_____	_____ to _____
Equilibrium Moisture	_____	_____ to _____	_____	_____ to _____
Hardgrove Grindability Index	_____	_____ to _____	_____	_____ to _____

Table 4 (continued)

Typical coal and ash analysis information suitable for boiler design

5. COAL ASH CHARACTERISTICS.

5.1 SLAGGING AND FOULING POTENTIAL. The slagging potential of ash is the tendency to form fused deposits on tube surfaces exposed to high temperature radiant heat. The fouling potential is the tendency of ash to bond to lower temperature convection surfaces. The slagging and the fouling potential of the coal also directly affects furnace design. Ash analyses of the expected fuel source must be performed before undertaking the boiler design, using ash prepared according to ASTM D3174.

5.1.1 FUSION TEMPERATURE. Many comparisons of chemical makeup have been developed to analyze the behavior of ash in boilers; empirical testing of ash fusion temperature is still the most basic way of predicting slagging and fouling potential. One testing method of determining ash fusion temperature is prescribed in ASTM D 1857. The test consists of observing the gradual thermal deformation (melting) of a pyramid shaped ash sample and recording the Initial Deformation Temperature (IT), Softening Temperature (ST), Hemispherical Temperature (HT), and Fluid Temperature (FT). The stages at which these temperatures are recorded are shown in Figure 4.

5.1.2 CHEMICAL ANALYSES. The fusion temperature of ash is influenced by the interaction of the acidic oxide constituents silica dioxide (SiO_2), aluminum oxide (Al_2O_3), and titanium dioxide (TiO_2) with the basic oxides; ferric oxide 2 (Fe_2O_3), calcium oxide (CaO), magnesium oxide (Mg_2O_3), and potassium oxide (K_2O); all of which are present in the coal ash in widely varying proportions. Depending on their relative proportions, they can combine during combustion to form compounds with melting temperatures ranging from 1610 degrees F for sodium silicate coal ash (Na_2SiO_3) to 2800 degrees F for calcium silicate (CaSiO_3) as shown in Figure 5. In determining the slagging potential and fouling potential of ash, studying the base/acid in ratio, silica/alumina ratio, iron/calcium ratio, iron/dolomite ratio, dolomite percentage, silica percentage, total alkalis, and the role of iron in coal ash is necessary. The chemical elements found in

coal, their oxidized forms, and the ranges in which they may be present in coal ash are listed in Table 5.

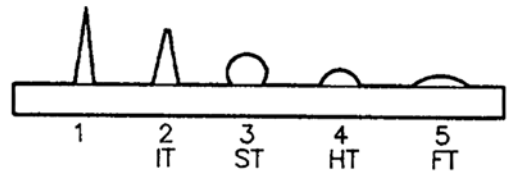

1. Cone Before Heating
2. IT (or ID) Initial Deformation Temperature
3. ST Softening Temperature ($H=W$)
4. HT Hemispherical Temperature ($H=1/2W$)
5. FT Fluid Temperature

Figure 4. Critical Temperature Points as Defined by ASTM Standards D 1857.

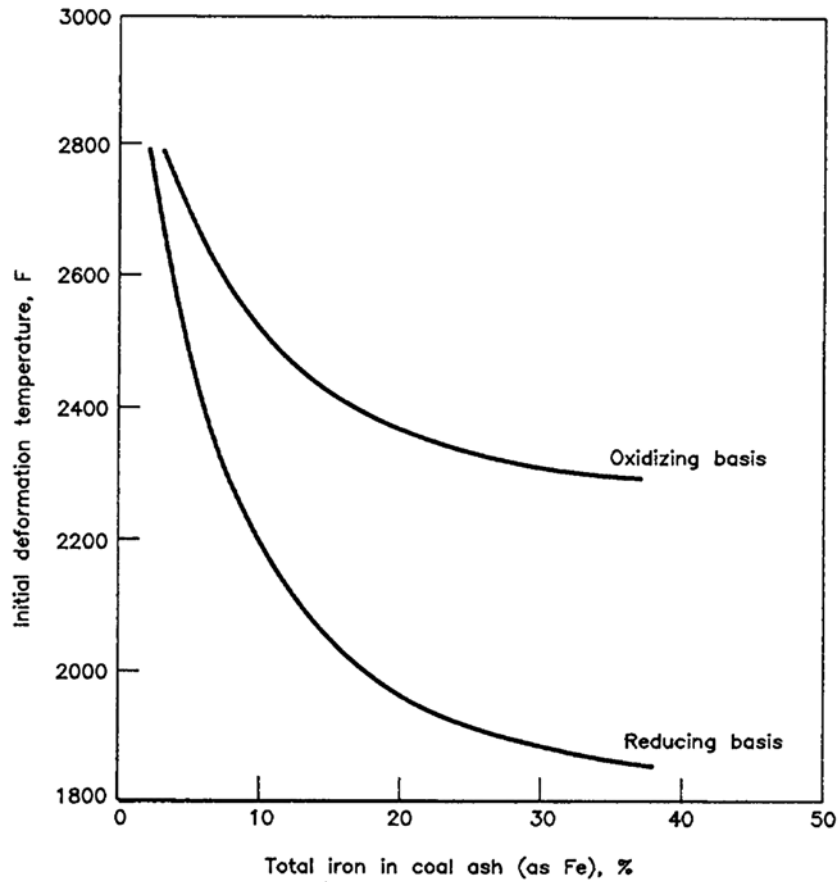

Figure 5. Influence of Iron on Coal Ash Fusion Temperatures.

Figures 4 and 5

Influence of iron on coal ash fusion temperatures

<i>Elemental Form</i>	<i>Oxidized Form</i>	<i>Range Present in Ash—%</i>
<i>Acidic</i>		
Si (silicon)	SiO ₂ (silica dioxide)	10—70
Al (aluminum)	Al ₂ O ₃ (aluminum oxide)	8—38
Ti (titanium)	TiO ₂ (titanium oxide)	0.4—3.5
<i>Basic</i>		
Fe (iron)	Fe ₂ O ₃ (ferric oxide)	2—50
Ca (calcium)	CaO (calcium oxide)	0.5—30
Mg (magnesium)	MgO (magnesium oxide)	0.3—8
Na (sodium)	Na ₂ O (sodium oxide)	0.1—8
K (potassium)	K ₂ O (potassium oxide)	0.1—3
S (sulfur)	SO ₃ (sulfur oxide)	0.1—10

Table 5
Chemical constituents of coal ash

5.2 ASH CHARACTERISTICS AND BOILER DESIGN. The characteristics and quantity of ash produced by a specific coal strongly influence several aspects of pulverized coal, ACFB and stoker boiler design, including the selection of a bottom ash handling system and furnace sizing. Ash with a high (2400 degrees F and above of a reducing basis) fusion temperature is most suitable for dry bottom boilers, while lower (1900 degrees F to 2400 degrees F on a reducing basis) ash fusion temperatures are required for wet bottom boilers to prevent solidification of the ash during low load

operation. Furnace volume must be increased for coals producing ash with high fouling and slagging potentials, or to counteract the erosive effects of large quantities of ash or very abrasive ash. The greater furnace volume results in both: lower exit gas temperatures reducing fouling and slagging, and lower exit gas velocities reducing tube erosion. The relationship between coal classification and furnace volume is shown in Figure 6.

6. COMBUSTION TECHNOLOGY SELECTION.

6.1 EXCLUSIONARY FACTORS. Gas and oil fired boilers are available over the entire size range. Their use is limited to areas where these fuels are economically available. Stoker-fired boilers are available for the entire load range covered by this publication. Pulverized coal (PC) boilers are available in capacities of 100,000 pph and above. Atmospheric circulating fluidized bed (ACFB) boilers are available in capacities of 80,000 pph and above. PC fired units were used in capacity ranges below 100,000 pph prior to the advent of package boilers, but with the new designs it became more difficult to evaluate PC firing as a preferred method of firing coal and hence have essentially become obsolete.

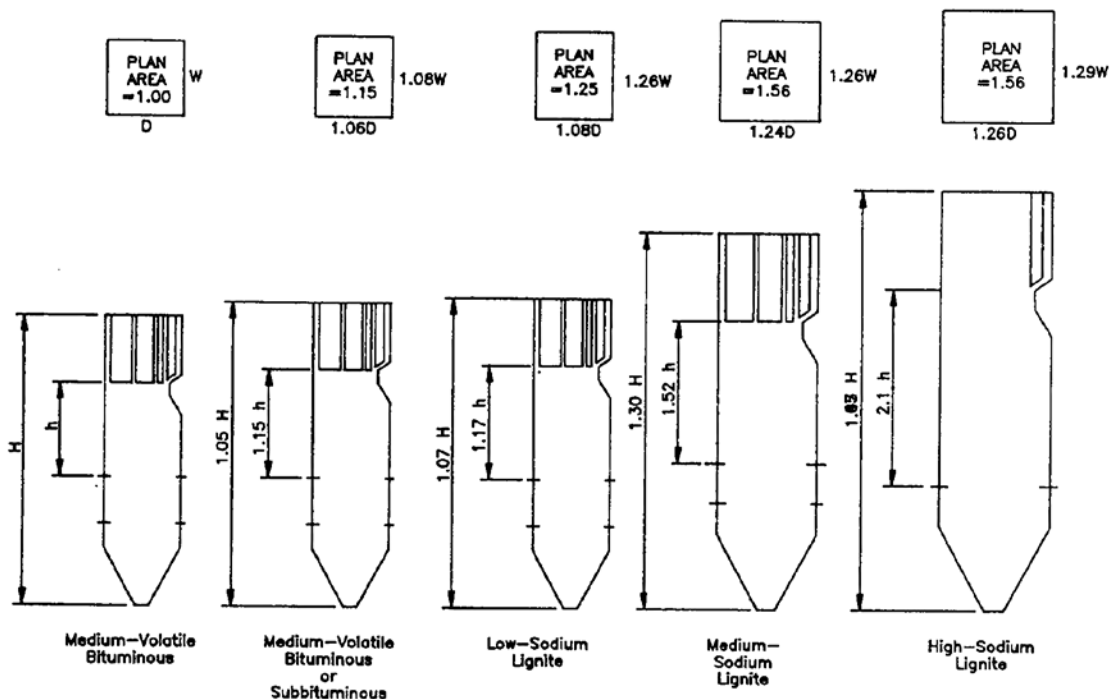

Figure 6

Effects of coal classification on furnace sizing

When rapid load swings are expected, stoker-fired units may be eliminated because of their inferior response to these conditions. When economics dictate the use of low grade fuels including those of high or variable ash content or high sulfur content then stoker-fired and PC systems may be eliminated in favor of ACFB systems. If none of these firing systems are excluded by these factors, then the choice between firing systems must be made on the basis of a life cycle cost analysis (LCCA).

6.2 BASE CAPITAL COST. The base capital cost of a dual firing system is the total price of purchasing and installing the entire system, including the boiler, furnace, either stoker, pulverizer or fluidization system, fans, flues, ducts, and air quality control equipment. PC fired and ACFB boilers are more expensive than stoker-fired boilers of a given capacity, in part because they have a larger furnace to provide space and time for the combustion process to go to completion. Approximately 60 to 90 percent of the ash content of the coal passes through the unit along with the gases of combustion. Tube spacing within the unit has to be provided in order to accommodate this condition and the ability of this ash to cause slagging and fouling of the heating surface. These factors can increase the size of the boiler and its cost. PC fired units have been replaced by packaged boilers in capacity ranges below 100,000 pph. Gas, oil and PC boilers require a flame failure system which increases their cost. The total cost of an ACFB boiler addition is offset by not requiring flue gas desulfurization (FGD) or selective catalytic reduction (SCR). Selective noncatalytic reduction (SNCR) is required on ACFB boilers in place of SCR.

6.3 AVERAGE BOILER DUTY. The remaining expenses calculated for an LCCA are all functions of the average boiler duty. This value is based on the estimated annual boiler load during the expected life of the plant. It is calculated as follows:

[average load (pph)/rated capacity] x [hours of operation/8760 hours] = average boiler duty

For example, if a 100,000 pph boiler operates at an average load of 75,000 pph for 8,000 hours per year out of a possible 8,760 hours, the average boiler duty is 68 percent.

6.4 FUEL FLEXIBILITY. When economically feasible the ability to satisfy steam requirements with more than one type of fuel offers significant advantages. Problems with only one fuel's source, transportation, handling or firing system will not stop steam production. The flexibility of alternate fuel supplies can be a powerful bargaining tool when negotiating fuel supply contracts.

6.5 FUEL SELECTION CONSIDERATIONS. The use of natural gas has the lowest first cost provided there is adequate supply in a nearby supplier's pipeline. Natural gas does not require storage facilities; however, it is subject to interruption and possible curtailment. Although diesel oil burns more efficiently than natural gas, oil requires on site storage and pumping facilities. Because oil has the potential to contaminate ground water, storage facilities are required to include spill containment and leak detection systems. Coal can be stored in piles outdoors. Steel tanks and spill containment are not required. Coal pile runoff (coal fines in rain water) into surrounding waters and airborne fugitive dust emissions are concerns that have to be addressed. Transportation of coal from stockpiles to the bunkers requires dedicated labor to operate unloading, storage, reclaim, and handling systems. These needs along with sizing, ash handling, and particulate emissions reduction requirements make coal firing the highest capital investment alternative.

6.6 SOLID FUEL CONSIDERATIONS. Due to the special coal sizing requirements of stoker and ACFB fuel for such a unit may cost (5 to 15 percent) more than the unsized coal that could be purchased for a PC fired unit. However, if unwashed or run-of mine (ROM) coal is purchased for a PC fired unit, a crusher and motor should also be included in the coal handling system in order to reduce the coal particle size to approximately 1-1/4 by 0-inch. Another consideration is that it may be difficult to obtain

the size stoker or ACFB coal due to either transportation difficulties or lack of equipment at a mine site. When using the same bituminous quality coal, PC and ACFB fired units have a higher thermal efficiency (86 to 88 percent) compared to stoker fired units (80 to 84 percent) that effectively lowers their fuel usage costs. The primary reason for these differences is unburned carbon loss and dry gas (exit gas temperature) losses and amount of fly ash rejection. These efficiency percentages will vary with the quality of the fuel. With low sulfur western fuels having a high moisture content (20 to 30 percent), a PC fired unit efficiency may be as low as 82 to 85 percent. A particular ACFB boiler can fire a wide range of low grade inexpensive fuels. These include high sulfur coal, petroleum coke, refuse derived fuel, waste water plant treatment sludge and mixtures of coal with various scraps such as shredded tires, wood chips and agricultural waste. Another feature of PC and ACFB fired units that result in increased costs and must also be considered in the overall evaluation is the natural gas or No. 2 fuel oil burner lighters which are normally in the range of 3 million to 10 million Btu per hour for each device. Stoker fired units are normally started by spreading kerosene or other waste oil and scrap wood over a coal bed and lighting it. Annual fuel cost is based on the cost of the fuel, in dollars and cents per million Btu multiplied by the hours of operation and average load and divided by the percent boiler efficiency.

6.7 POWER COST. Gas fired boilers have the lowest electrical energy requirements. Oil fired units are next due to oil pumping and heating needs. Auxiliary power requirements for gas and oil boilers are considerably less than coal fired units because ash handling, coal handling, sorbent handling and pollution control systems are not needed. A comparison can be approximated by listing the fan and drives with their respective duties and the sizes of each. For example, on a PC fired unit there are forced draft (FD) and induced draft (ID) fans and drives, primary air (PA) fan(s) and exhaustor(s) and drive(s) and pulverizer drive motor(s). It is possible the primary air fan or exhaustor drive and pulverizer drive motor may be combined so there is a single motor driving both devices. Normally, there would be two or more pulverizers and PA or exhaustor fans per boiler unit. For the stoker fired unit, there are also an FD and ID fan

drive, and an overfire air and ash reinjection system that likewise may be combined as a single piece of equipment. The pulverizer drive and primary air fan and exhaustor drive are relatively high duty or horsepower (hp) consumers compared to the stoker overfire air and ash reinjection system fan drive together with the stoker drive motor. Annual power costs, kilowatt hours per year, is directly related to average boiler duty. Sootblower motors are fractional horsepower and generally are not included in any power comparison. ACFB boilers also have high electrical power requirements. The fluidized bed is suspended on air that is provided by a primary air fan. The solids reinjection device has fluidizing air needs which are provided by blowers. Limestone handling is another electrical user which is unique to ACFB. Inert bed handling is also in this category. ACFB boilers, however, unlike PC and stoker boilers, may not require sulfur removal equipment such as scrubbers. This must be considered when evaluating power cost.

6.8 MAINTENANCE COSTS. Gas fired boilers have the lowest maintenance cost. Oil fired boiler installations are higher than gas fired systems due to oil pumping needs, oil storage requirements and boiler corrosion and external deposits on heat transfer surfaces resulting from sulfur, sodium and vanadium in the oil. ACFB boilers have higher maintenance when compared to PC boilers. The abrasive action of the solids circulating through the combustor and solids separator causes wear. ACFB systems are more complicated with more components which add to the maintenance cost. As more ACFB experience is gained, maintenance costs can be expected to decrease as improvements are made. Maintenance costs for a PC fired unit are generally higher than that for a stoker fired boiler due to the higher duty requirements of such items as the pulverizers, primary air fans or exhaustors, electric motors, coal lines and greater number of sootblowers. Maintenance costs are also a reflection of the hours of operation and average boiler duty.

6.9 OPERATING COSTS. These expenses include manpower, sorbent, and other costs incurred on a continuing basis while the plant is in operation. Manpower

requirements for oil fired boilers are somewhat higher than gas boilers, because of the fuel storage and increased handling concerns associated with oil. Coal fired technologies require considerably more manpower than either oil or gas. Fuel handling, ash handling and pollution control systems account for the majority of the increase in operating costs. Even though stoker fired and PC boilers are less complicated than ACFB boilers, stoker and PC boilers, unlike ACFB boilers, must include scrubbers. The evaluation of operating costs among coal firing technologies is site specific and must include all relevant factors.

7. PULVERIZERS (MILLS)

7.1 TYPES. There are four basic types of pulverizers frequently used on industrial sized boilers. They are commonly referred to by the type of grinding elements, i.e., ball and tube, attrita, ball-and-race, and ring-and-roll.

(1) The ball and tube type mill is commonly used on boilers that use coal as the principle fuel. They require more space and use more power input than the other types, so they are at an economic disadvantage unless only one mill is used.

(2) Attrita type mills are usually used on boilers that use gas or oil as the primary fuel with coal as a backup fuel. These mills are subject to high maintenance due to the use of unwashed (ROM) coal and foreign objects (rail, spikes, rebar, wood) getting into the coal stream. This mill combines the pulverizer and the exhauster in a single package.

(3) The following information and illustrations primarily pertain to the more frequently used ball-and-race and ring-and-roll type mills. Figures 7 and 8 illustrate the two more commonly used pulverizer types.

7.2 CAPACITY. Pulverizer capacity is a function of coal type, based on a grindability index, moisture content, and fineness of the product. At least two pulverizers should be provided, and with one pulverizer off line for maintenance the remaining pulverizers should be capable of supplying coal to the boiler at the desired load with worst case coal. Figures 9, 10 and 11 show the influence of grindability and moisture content of coal on pulverizer operation.

8. COAL BURNER IGNITORS.

8.1 TYPES. Natural gas or No. 2 fuel oil ignitors are required for firing pulverized coal. These ignitors will be capable of preheating the boiler prior to starting the pulverizer and firing coal. The ignitors should be able to carry about 10 percent of maximum continuous rating (MCR) and are also used to stabilize the coal flame when the burner load is less than approximately 40 to 50 percent or other adverse fuel conditions such as high moisture. The steam load, at which the pulverized coal flame has to be stabilized, should be investigated in the design stage so that suitable auxiliary fuel provisions can be designed into the plant. If oil ignitors are used, either compressed air or steam atomizers are used. Pressure on mechanical atomization should not be considered due to safety factors.

8.2 COST. The cost of these ignitors and the labor required for their installation plus the fuel system required should be included in the LCCA. Ignitors will be lit by high energy spark plug type lighters.

9. BURNERS AND NO_x CONTROL

9.1 BURNER DESIGN. State of the art burner design calls for low excess air operation to improve the boiler thermal efficiency (reduced exit gas temperature and dry gas loss) as well as to reduce NO_x emissions. Coal burners will be specifically designed for pulverized coal and compatible with the gas or oil ignitors to be supplied and produced by a qualified manufacturer. Note, in the case of gas, oil and pulverized coal fired units, a flame safety systems required.

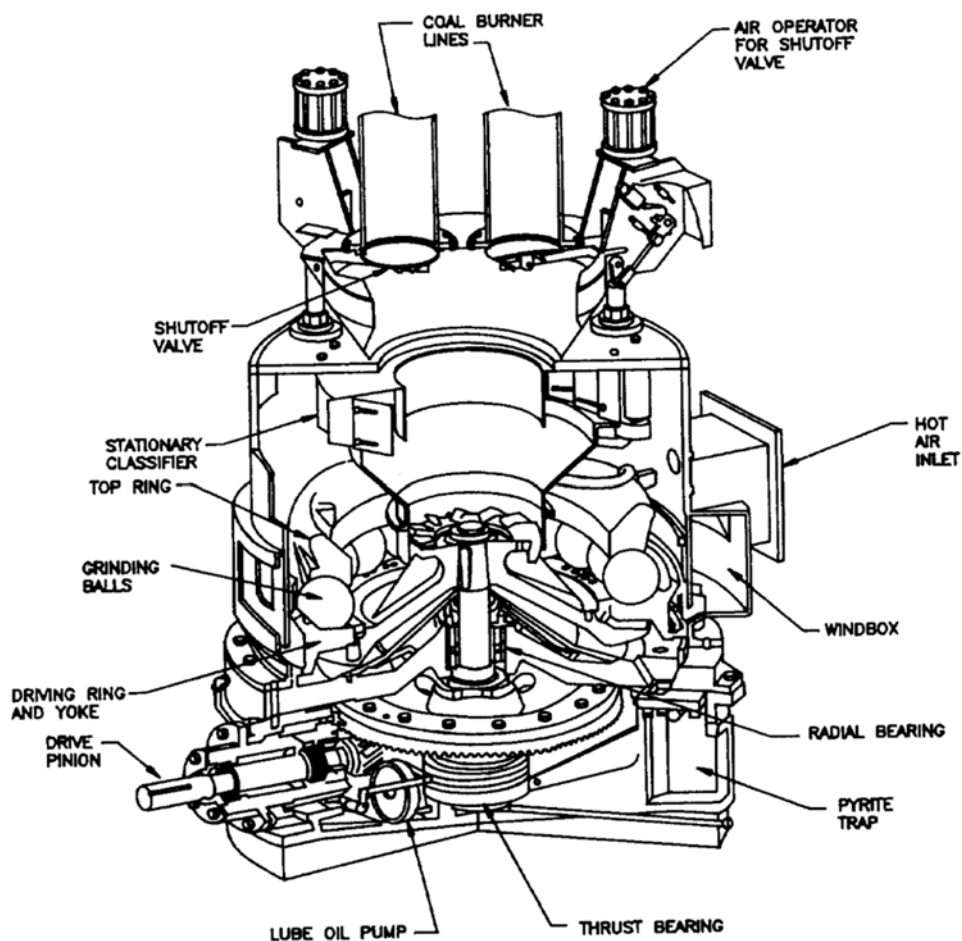

Figure 7

Ball and race pulverizer

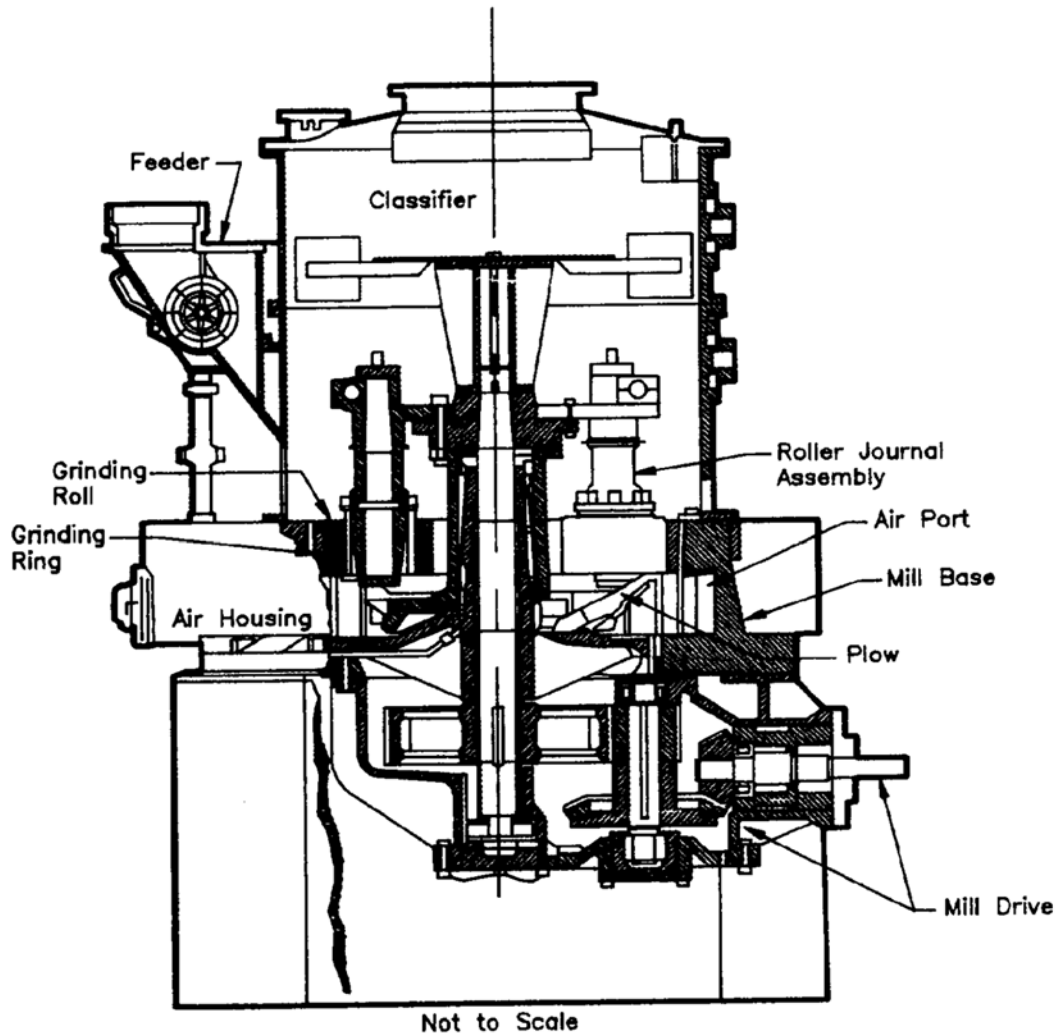

Figure 8
Ring-and-roll pulverizer

9.2 FLAME SAFETY DETECTORS.

(1) Ultra violet type detectors are used on natural gas and some oil fuels, but will not be used on pulverized coal boilers since the flame masks most of the light rays of that type.

(2) Infrared type detectors are used on pulverized coal boilers to detect coal fire. (3) For reliability, with a suitable life span, solid state type controls should be used for the detectors.

9.3 NO_x CONTROL OPTIONS AND CONSIDERATIONS. Many options are available to reduce NO_x emissions as mandated by recent regulations. The nitrogen content of fuels, especially oil and even coal, should be specified in the fuel purchase contract. Restrictions on the nitrogen content will limit fuel flexibility. A careful analysis of proposed NO_x reduction technologies must be performed to account for any required changes to auxiliary equipment and to identify future increases in O&M costs. Important questions that should be answered and be a part of the evaluation include the performance of NO_x reduction over the entire load range, performance during backup fuel firing, and the performance over the lifetime of the unit.

(1) Harmful effects of NO_x on the environment include contributions to acid rain, to the destruction of the ozone layer, to global warming, and on smog.

(2) Components of NO_x include nitric oxide (NO), nitrogen dioxide (NO₂), and nitrous oxide (N₂O) as a residual pollutant of some NO_x control processes. Emissions from combustion processes are 90 to 95% NO with the balance being NO₂.

(3) Title IV of the Clean Air Act Amendments of 1990 (CAAA) requires application of low NO, burner (LNB) technology. Title I of the CAAA has more impact in ozone nonattainment areas which are near the nation's largest cities. State implementation plans may place even more strict limits on NO Flexibility by having provisions for averaging NO emissions over the system.

(4) NO is formed as a result of oxidizing various sources of nitrogen. Fuel NO is formed when the nitrogen contained in the fuel is oxidized.

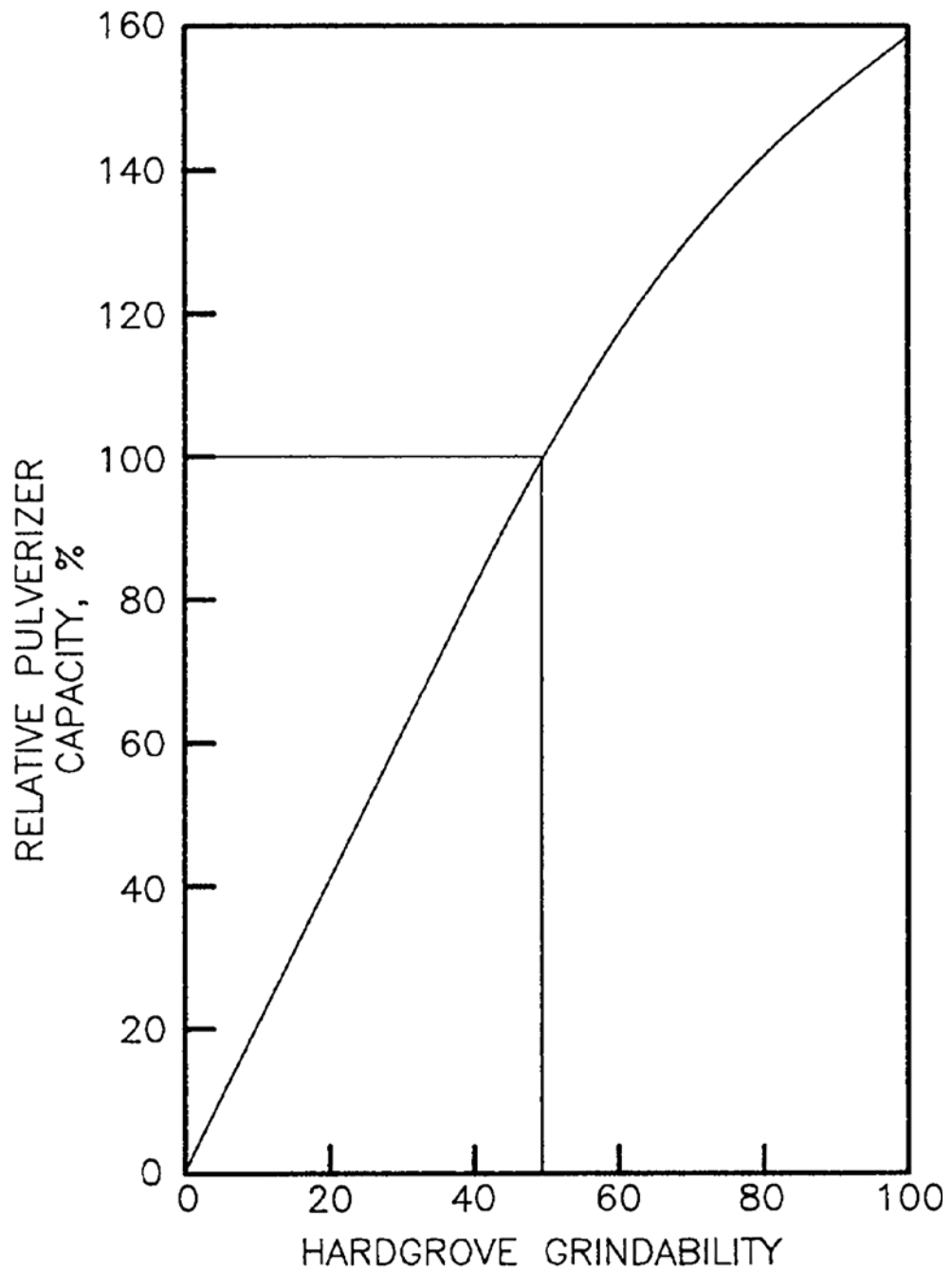

Figure 9

Relative pulverizer capacity as a function of Hardgrove grindability

Thermal NO_x results from the oxidation of nitrogen in the combustion air at high temperatures. At very low levels of NO_x, prompt NO_x is formed when intermediate hydrocarbons present in the flames oxidize.

(5) NO_x control techniques can be defined as either combustion modifications or post combustion reduction. The goals of combustion modification include redistribution of air and fuel to slow mixing, reduction of O₂ in NO_x formation zones, and reduction of the amount of fuel burned at peak flame temperatures.

(6) Combustion modifications primarily deal with the control of fuel and air. Vertical staging includes overfire air (OFA) ports above the main combustion zone. Horizontal staging use registers or other devices to introduce air at different points along the flame. Fuel staging establishes a fuel rich zone above an air lean main combustion zone. Burner out of service (BOOS) techniques direct fuel to lower burner levels, while operating upper burners with air only. Flue gas recirculation (FGR) reduces O₂ available to react with nitrogen and cools the flame. In addition to low NO_x burners

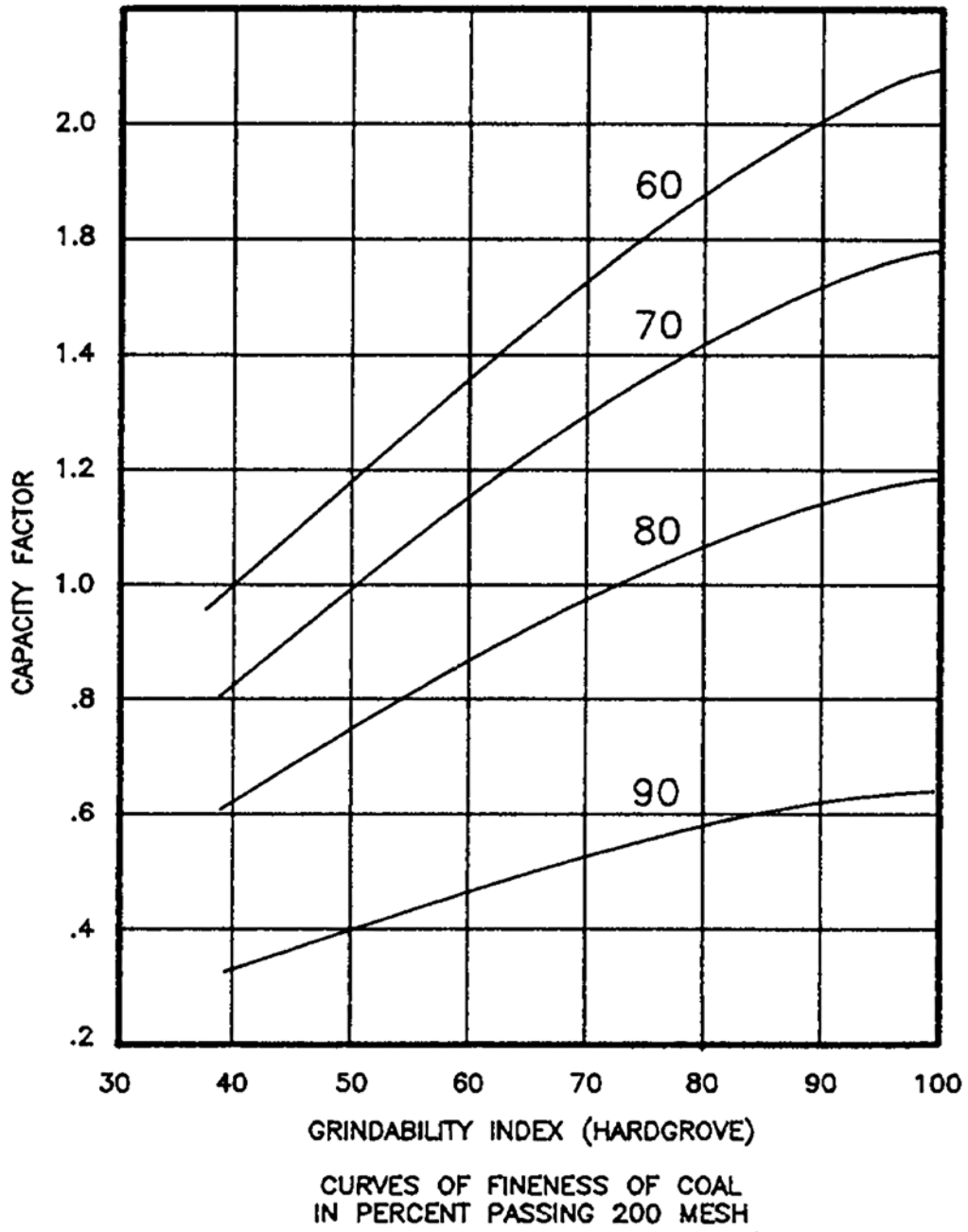

Figure 10

Effect of fineness on capacity of pulverizers

(LNB), OFA, and BOOS, other combustion modification techniques include fuel biasing, low excess air (LEA), and fuel reburning. Oil fired boilers have successfully used advanced oil atomizers to reduce NO_x without increasing opacity. Oil/water emulsion is a technique to reduce NO_x on smaller industrial boilers.

(7) NO_x reduction side effects should be considered in the evaluation of alternatives. Reduction techniques may require constant operator attention or a high degree of automation. LNB's on coal fired boilers increase carbon loss in the ash by 0.5 to 10% which may require the installation of classifiers and reinjection lines. Loss on ignition (LOI) reduction techniques have other impacts. Classifiers may place constraints on pulverizers which decrease operation flexibility. Unit efficiency may decrease if excess air has to be increased. Changes in slagging patterns may occur. Soot blowing may be needed more frequently. Difficulties may arise during changes in load. Mechanical reliability may decrease. Burner barrel temperature is difficult to control with some LNB's which leads to premature failure. Corrosion potential increases because highly corrosive hydrogen sulfide forms instead of SO₂ due to the reducing atmosphere. Changes in flame length can cause impingement and can alter heat absorption characteristics. Fly ash loading may increase at the air heater or particulate collection equipment.

(8) Selective catalytic reduction (SCR) uses ammonia as reagent to reduce NO_x to water and elemental nitrogen. SCR offers 90 percent or greater NO_x removal. Reactions take place between 1600 degrees F and 2200 degrees F. Catalyst is needed to promote reactions at lower temperatures. Catalyst life is guaranteed up to 5 years and has reportedly been as long as 10 years. Catalyst replacement is the largest part of O&M costs. The other popular form of post combustion technology is selective noncatalytic reduction (SNCR). SNCR involves the injection of either urea, ammonium hydroxide, anhydrous ammonia, or aqueous ammonia into the furnace within the appropriate temperature window (1600 degrees F to 2000 degrees F) to reduce NO_x. Some of the NO_x is converted to N₂O which is considered a "green house" gas.

Ammonia emission of “slip” is another concern. SCR concerns include fouling or blinding catalyst surfaces and poisoning the catalyst with arsenic, lead, phosphorus or other trace compounds found in coal.

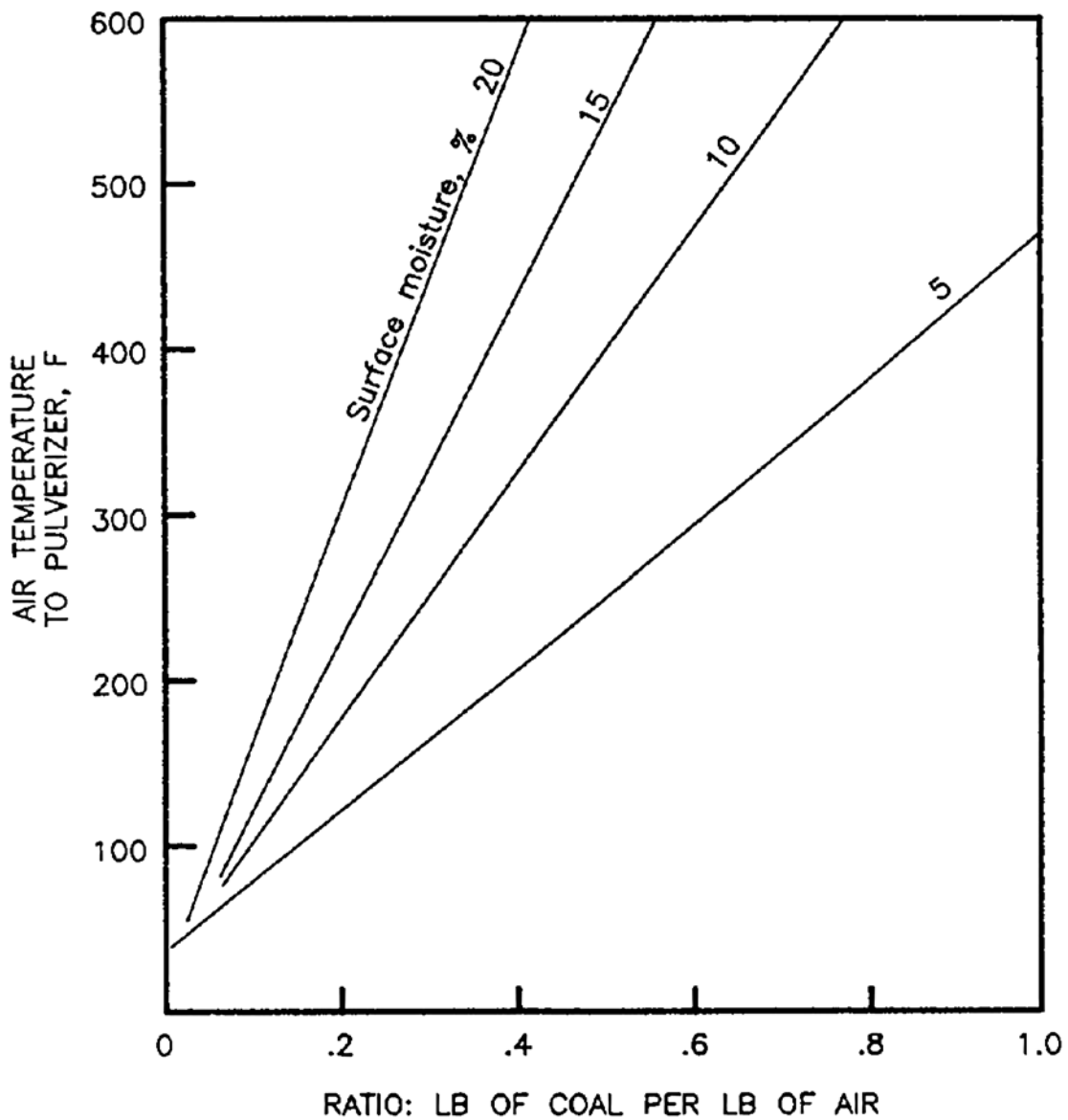

Figure 11

Effect of moisture on pulverizer air temperature requirements

(9) Operation and maintenance cost increases should be identified. Coal boiler bottom ash systems may have to be retrofitted with ash separators and carbon recovery devices if LOI increases substantially. Ash sold for reuse may no longer be attractive and could even be considered hazardous waste. As regulations become more strict

additional catalyst could be needed to meet NOx emissions and ammonia slip. Changing fuels could have detrimental effects on existing NOx reduction equipment.

(10) Installation and retrofit of various NOx reduction systems have unique installation and space requirements that should be considered. LNB may or may not require pressure part modifications. FGR involves routing large ductwork. OFA is very effective, involves routing of ductwork, and also involves modifications to pressure parts. Fuel staging requires pressure part modifications for reburn fuel injection and/or OFA ports.

10. PRIMARY AIR.

10.1 AIR MOVING SYSTEM. Pulverized coal firing requires heated primary air to dry the surface moisture in the coal fed to the pulverizers and to provide the conveying medium for getting the finely ground pulverized coal from the pulverizer to the burner and out into the furnace. This primary air is supplied either by the FD fan for a hot primary air system or a separate cold primary air fan for pressurized pulverizer systems; or is drawn through the pulverizer by an exhauster fan in the negative pressure pulverizer system.

(1) The use of a separate high pressure fan to force the coal through the mill and burner lines to the furnace burner and out into the furnace itself requires all the burner piping and pulverizer to be sealed against this pressure in order to prevent coal leaks.

(2) In the negative pressure pulverizer operation, the exhauster fan pulls the air through the mill and then forces it up through the riffle box, then the burner lines to the furnace. In this case, any leakage would be into the mill. However, the burner lines are under pressure and any leakage would result in finely ground coal showing up around these leaks.

10.2 COAL AIR MIXTURE. In either case, pressure or exhauster type mills, the coal-air mixture is usually at a temperature of approximately 150 degrees F and a velocity 2000 feet per minute (fpm) or higher to prevent the coal from settling out in the burner lines. If the coal does settle out in these burner lines, fires or explosions in the burner lines or pulverizers may occur.

11. STOKERS.

11.1 TYPE. Mechanical stokers continuously supply coal to their grates in a manner that allows for controlled combustion of the coal. There are several combinations of stokers and grate types hereafter referred to as stoker types and are available for use in coal fired boilers with steam capacities of 20,000 to 250,000 pph which is the entire range covered by this manual. However, not all of them are acceptable for state-of-the-art boiler plant design.

11.2 UNACCEPTABLE STOKER TYPES.

(1) DUMP GRATE STOKER. This type of stoker is not recommended because it has a high particulate emission rate whenever the grates are dumped. This factor necessitates added cost for air pollution control equipment due to the increased size required to handle the dust loading. Maintenance costs are relatively high. However, one use of this type of stoker that may be desirable is in conjunction with a pulverized coal fired unit for the reduction of refuse derived fuel (RDF) at the furnace hopper outlet. The use of this type of stoker in the described application will prevent large particles of refuse that fall to the bottom of the furnace from being dumped into the furnace ash travel pit before having been completely consumed in the combustion process.

(2) SINGLE RETORT UNDERFEED STOKER. This type of stoker is not recommended to be used in boilers with steam capacities above 25,000 pph which is at the low end of the size range addressed by this manual. Because of its limited application, the single retort underfeed stoker will not be considered.

(3) MULTIPLE RETORT UNDERFEED STOKER. This type of stoker is a grouping of the single retort underfeed stokers to increase potential applications of the underfeed retorts for boilers with steaming rates over 25,000 pph. It is not recommended because of high costs for installation and maintenance.

11.3 ACCEPTABLE TYPE STOKERS.

(1) VIBRATING OR OSCILLATING GRATE STOKER. This type of stoker is available for boilers with steam capacities between 20,000 and 150,000 pph, depending upon what feed types are used. It is available with either mass feed or spreader feed.

(2) TRAVELING GRATE STOKER. This type of stoker moves the coal through the boiler furnace on a continuous belt made of the stoker grate bars. Combustion air passes through the grate bars to reach the fuel bed. The combustion air pressure drop across the grate due to the construction of the grate bars is evenly distributed to the fuel at all loads. This design feature makes the traveling grate stoker acceptable for use with spreader type coal feed. For mass burning, plenums and dampers must be incorporated into the design of the stoker. The traveling grate stoker is acceptable for boilers with steam capacities of 50,000 pph and above.

(3) TRAVELING CHAIN GRATE STOKER. This type of stoker moves the coal through the boiler furnace a continuous belt made of interlocking links or bars. Unlike the traveling grate stoker, it has a low pressure drop across the chain due to the spaces between the links. As a result, the air flow on this type of stoker is not evenly distributed at all boiler loads. Therefore, the traveling chain grate stoker is acceptable only with a mass type feed in boilers with steam capacities between 20,000 and 75,000 pph.

12. STOKER FEED.

12.1 TYPES. Two types of stoker feed are available for use with vibrating grate and traveling grate stokers; cross-feed (or mass feed) and spreader feed distributor (or flipper). Selection of one type or other of these stokers will depend primarily on a comparative analysis of the capital and operating costs associated with the pollution control equipment needed for these feed types. With the traveling chain grate, only a mass fuel feed type will be used.

12.2 CROSS FEED. This type of stoker feed is a mass fuel overfeed in which coal is placed directly on the grates from a coal hopper. Continuous feed is automatic as a fuel bed moves away from the coal hopper. This type of fuel feed must have adjustable air dampers under the fuel bed to control combustion zones. The depth of the fuel bed is generally controlled by a gate.

12.3 SPREADER FEED. This type of stoker feed throws coal to the rear of the furnace and evenly distributes coal from side to side with a small degree of segregation. Approximately 25 to 50 percent of the coal is burned in suspension by this method. This spreader feed has a larger grate heat release rate than the cross feed type; requires a smaller furnace envelope; and has a quicker response time for load changes. This type of fuel feed must have a uniform air flow through the grates due to the large amount of suspension burning. For best results, the fuel fed to this type of unit should be properly sized. Refer to Figure 12 illustrating coal size.

12.4 STOKER SELECTION CONSIDERATIONS. Table 6 provides a summary of factors to be considered when selecting a stoker for a boiler within the range of 20,000 to 250,000 pph of steam. Prior to submitting a set of specifications to the boiler or stoker manufacturers, the type of coal that is to be burned must be known. Selection of the design coal is required so that these manufacturers are able to guarantee their equipment performance. When the coal is not known, or when the possibility exists that

many different types of coals will be burned over the life of the stoker, the selection emphasis should lean toward spreader stokers. This type of stoker is more flexible in its capability to efficiently burn a wider range of coals.

13. FLY ASH REINJECTION FOR COAL FIRING.

13.1 GENERAL. A fly ash reinjection system for coal fired boilers is used to return coarse, carbon bearing particulate back into the furnace for further combustion. This is only economically justified in stoker fired boilers with steam capacities over 70,000 pph. Fly ash reinjection from the boiler, economizer, air heater and dust collector hoppers can improve boiler thermal efficiency by 3 to 5 percent. However, fly ash recirculation within the boiler is significantly increased.

13.2 EQUIPMENT SIZING. Tube erosion and other maintenance costs in addition to requiring an increase in the capability of the air pollution control equipment are to be expected and must be taken into consideration when sizing the air pollution control equipment.

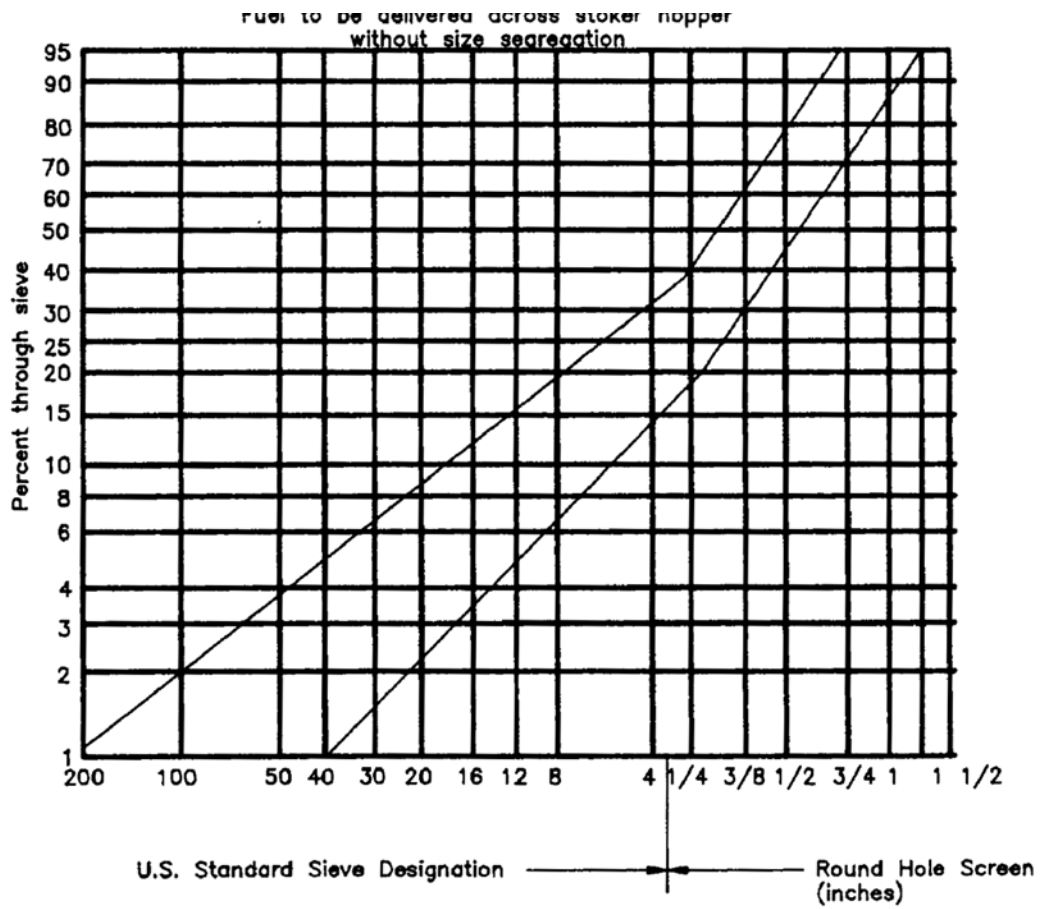

Figure 12

Coal sizing chart: recommended limits of coal sizing for spreader type stokers

	<i>Vibrating Grate Stoker</i>		<i>Traveling Grate Stoker</i>		<i>Traveling Chain Grate Stoker</i>
	<i>Crossfeed</i>	<i>Spreader Feed</i>	<i>Crossfeed</i>	<i>Spreader Feed</i>	<i>Crossfeed</i>
Applicable Boiler Size, pph	100,000- 150,000	20,000- 150,000	100,000- 250,000	50,000- 250,000	20,000- 75,000
Maximum Grate Heat Release, Btu/ft ² -hr	400,000	600,000	450,000	750,000	450,000
Maximum Furnace Heat Release, Btu/ft ² -hr	25,000	25,000	25,000	25,000	25,000
Coal Parameters					
Moisture %	0-10	0-10	2-15	0-10	2-15
Volatile Matter %	30-40	30-40	30-45	30-40	30-45
Fixed Carbon %	40-50	40-50	40-55	40-50	40-55
Ash %	5-10	5-10	6	5-15	6
Btu/lb (Min)	12,500		11,000		11,000
Free Swelling Index (Max)					5
Ash Softening Temp, F (Reducing Stimulus)	2,300	2,300	2,200	2,300	1,900
Coal Size	1"x0"	1-1/4"x3/4"	1"x0"	1-1/4"x3/4"	1"x0"
Max Fines thru 1/4" Screen Max	40%	50%	60%	40%	60%
Stoker Turndown ¹ (Stable Fire)	3:1	3:1	3:1	3:1	3:1
Particulate Emissions 10' Btu	1.0-1.5	1.4-10	0.6-1.5	1.4-10	0.6-1.5

¹ To achieve this turndown rate, reference should be considered in the construction of the boiler for either membrane or welded wall construction or tube and tile type construction. Note some loss in boiler thermal efficiency will occur at lower loads.
Note: Coal sizing and quality have a direct influence on the efficiency of stoker fire boilers. These selection factors do not apply to those western fuels which have high moisture 25 percent or more content and have a lignite type ash characteristic.

Table 6
Stoker selection factors

14. OVERFIRE AIR.

14.1 GENERAL. Overfire air is the ambient air supplied by either the FD fan or a separate fan that may also be used for fly ash reinjection and is used on all types of stoker fired boilers. The purpose is to aid combustion and to ensure the coal particles are as completely burned as possible.

14.2 PORT LOCATION. Overfire air ports are located on either or both the front and rear furnace walls.

15. ATMOSPHERIC CIRCULATING FLUIDIZED BED (ACFB) BOILER COMPONENTS.

15.1 LOWER COMBUSTOR. Fuel is fed into the refractory lined lower combustor section where fluidizing air nozzles on the floor of the combustor introduce air which controls the velocity of solids through the combustor. Ash must be removed from the bottom of the combustor to control solids inventory, bed quality, and prevent agglomeration of solids. Arrangement of tuyeres or air distribution devices must direct ash flow toward bed drains. Figure 13 shows the major ACFB boiler components.

15.2 UPPER COMBUSTOR AND TRANSITION ZONE. The upper combustor is waterwall design. Solids and gases leave the combustor through a transition section which must account for three dimensional thermal expansion between the major boiler components.

15.3 SOLIDS SEPARATOR. The transition section with expansion joint connects the combustor to a solids separator. Two different separator designs include

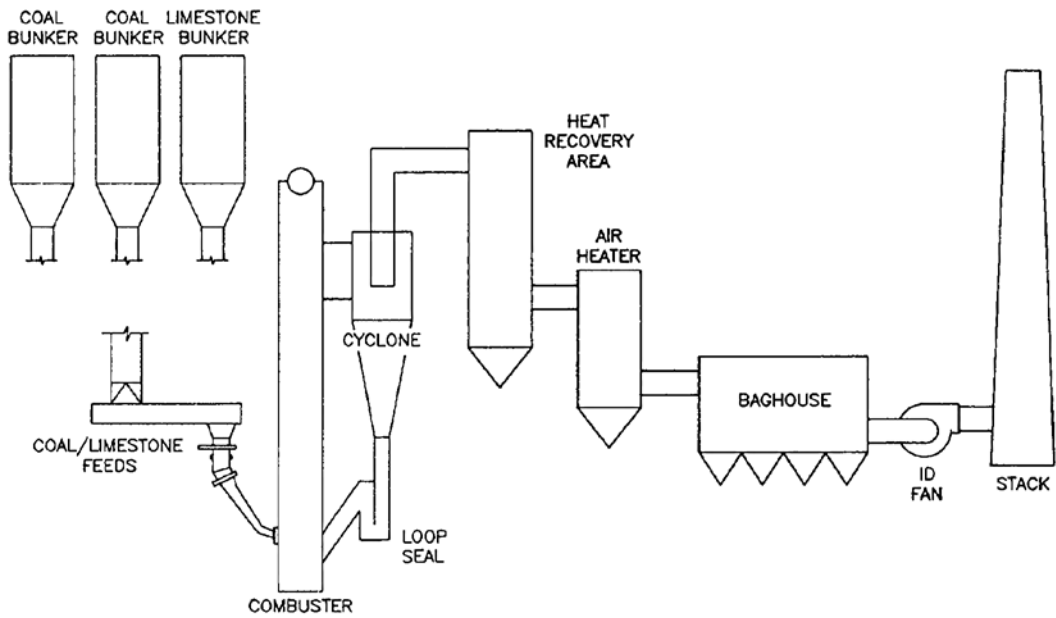

Figure 13
Atmospheric circulating fluidized bed boiler

mechanical cyclone type and U beam. Cyclone separators are more common. Cyclones can be either water or steam cooled to reduce refractory thickness.

15.4 SOLIDS REINJECTION DEVICE. Solids that have been removed in the separator are reintroduced into the combustor for additional carbon burnout and increased combustion efficiency. This recirculating loop is sometimes referred to as the “thermal fly wheel.” Solids reinjection devices consist of a refractory lined pipe with fluidizing air nozzles. This device is frequently called either a J-valve, L-valve or loop seal. Sorbent for sulfur capture enters the boiler either through the reinjection device or through separate feeders into the lower combustor section.

15.5 EXTERNAL HEAT EXCHANGER (EHE). One design includes the use of an EHE to recover heat from recycled solids. Most manufacturers do not use an EHE due to problems encountered.

16. BOILER COMPONENTS.

16.1 SUPERHEATERS. Superheaters receive saturated steam from the boiler steam drum after having gone through the steam and water separating components within the steam drum. This steam should have a purity of 1 part per million (ppm) or better depending on the quality of the boiler water. The superheater is sized so as to add sufficient heat to the steam to obtain the desired final steam temperature. For units with a final steam temperature of no more than 700 degrees F, boiler manufacturers will normally use a single section style superheater. Superheaters on coal fired units are of the pendant type and hence are not drainable. Further, superheaters are either exposed to the radiation of the fire in the furnace, or are located above a "nose" usually on the rear furnace wall that provides for a radiant-convection superheater surface. The design and construction of superheaters is in accordance with the ASME Boiler and Pressure Vessel Code that applies to the boiler. Normally, superheaters for boilers covered by this manual, will have tubes made of carbon steel, either SA-210 or SA-192, whereas the saturated or water carrying tubes of the boiler and furnace will be made of carbon steel type SA-178.

(1) For proper operation, particularly of pendant, nondrainable type superheaters, fluid pressure drop is needed to provide proper distribution of the steam through the tubes. It is desirable to locate the steam outlet connection at the center of the superheater outlet header for proper steam distribution, but end outlets are acceptable if proper design consideration is given to the flow distribution imbalances caused by the header configuration.

(2) A factor to be considered about superheater pressure drop is the power cost required for the boiler feed pump. The higher the pressure drop, the more pump power is required.

(3) Another factor to be considered in a super-heater design is the flue gas velocity over the outside of these tubes. This flue gas velocity should normally be in the range of 55 to 60 feet per second (fps) in order to avoid external tube erosion from the fly ash particles entrained in this gas.

(4) Another factor to be considered for units with superheaters is the outlet steam piping and the shutoff valves. As the temperature approaches 700 degrees F at the superheater outlet, the steam piping material can be either SA-106B or 106C. This material has an allowable limit of 800 degrees F and a maximum allowable stress of 10,800 and 12,000 pounds per square inch (psi), respectively. The higher the steam temperature, the better and more expensive the steam piping material should be.

16.2 AIR HEATER. Either recuperative (tubular) or regenerative (rotating plate type) air heaters may be used to heat combustion air on stoker fired boilers

16.3 STEAM COIL AIR PREHEATERS. Steam coil air pre-heaters are used to heat air entering the air heater, recuperative or regenerative type, in order to raise the average cold end temperature to prevent acid dewpoint corrosion. This type of equipment is normally incorporated into the design of a boiler unit for low load operation and startup operation particularly in those areas with low ambient air temperatures. They are desirable in that the main air heaters, recuperative or regenerative, have corrosion sections that are more readily maintained. This type of air heater uses extended surface, normally referred to as fins, to reduce the overall size of this air preheater. The air pressure drop through the steam coil air preheater is generally limited to about 1 inch of water. It is generally located in the duct between the FD fan and the main air heater. However, in those areas that have extremely low ambient air temperatures, it is not uncommon to have an air preheater ahead of the FD fan that could preheat cold winter air up to about 40 degrees F, firing lignite or subbituminous coal or any coal that has an inherent moisture content greater than 15 stoker fired boilers where the coal being burned has a caking tendency. Coal of the caking type is normally associated with

areas such as the Midwest. Air heaters are required on pulverized coal and ACFB fired boilers to heat the combustion air and the primary air. The use of either a recuperative or regenerative type air heater may be determined by space requirements, desired exit gas temperature, maintenance and related costs and other factors involved in a LCCA. The air heater reclaims some of the heat energy in the escaping flue gas and adds that heat to the air required for the combustion of the fuel. This not only decreases the heat loss to the stack, but also decreases the excess air required at the burner. Each 100 degrees F increase in air temperature represents an increase of about 2 percent in boiler unit efficiency.

(1) The source of the steam is normally low pressure, 100 psig or less, and it is frequently the exhaust steam from some other piece of equipment such as a steam turbine drive or other process that exhausts steam at a pressure of 15 psig or higher.

(2) When justified by a LCCA, the steam coil preheater drains may be individually piped to a receiver tank. Drains to this receiver tank may need to be heat traced to prevent freezing. If a receiver tank is not justified by the LCCA, the air preheater drains will be piped to wastewater drains. The piping arrangement should conform to the steam coil manufacturer's recommendations. However, it should be noted that this is treated water and the cost for treating should be included in the cost analysis.

16.4 ECONOMIZERS. Only bare tube economizers should be used on any coal fired boiler. Finned tube (extended surface) economizers should not be used on coal fired boilers as they are more susceptible to both pluggage and corrosion when used in

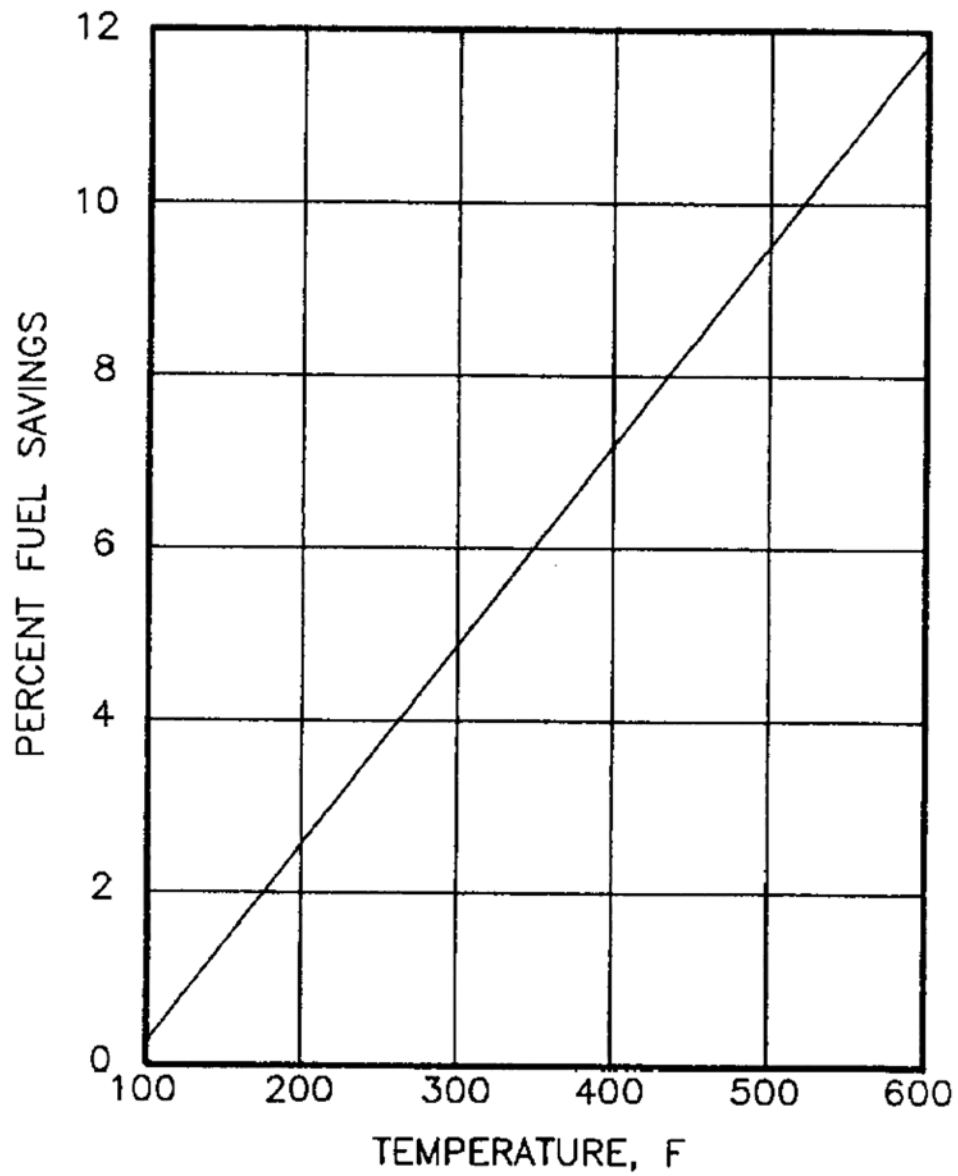

APPROXIMATE IMPROVEMENT IN EFFICIENCY
WHEN HEATED COMBUSTION AIR IS USED
IN BOILER UNITS.

Figure 14
Air heater fuel savings

conjunction with coal fired boilers. Another desirable feature of the bare tube economizer is that the tubes should be “in line” so as to have clear spaces between each tube. This arrangement enables the sootblowers to keep the gas lines clear. Extended surface economizers for gas and/or oil fired units offer economic advantages when compared to bare tube economizers. Extended surface economizers are lower first cost and have smaller installation space requirements. For oil fired boilers, fin spacing should take into account the particular grade of oil to avoid fouling problems.

(1) The purpose of the economizer is to raise the temperature of the boiler feedwater while lowering the flue gas temperature. Economizer surface is usually less expensive than heating surface in either the furnace area or the boiler convection tube bank.

(2) In order to provide the required primary air temperature, economizers may not be used on some pulverized coal fired units. They are generally used on all gas, oil, and stoker fired boilers as indicated above, and may be the only type of heat recovery used on some stoker fired boilers and the only type used on gas/oil fired boilers. Economizer sections on ACFB boilers are sometimes called “heat recovery areas (HRA)” and are an integral part of the boiler. Economizer fuels (coal, oil, gas) steam generator efficiency increases about 2.5 percent for each 100 degrees F drop in exit gas temperatures. By putting flue gas to work, air heaters and economizers can improve boiler unit efficiency by 6 to 10 percent and thereby improve fuel economy. Refer to Figure 15 for fuel savings based on reduction of exit or flue gas temperature. Normally an economizer is less costly and requires less space than an air heater.

16.5 SOOTBLOWERS. Sootblowers are used on all heavy oil and coal fired boilers to clean ash deposits from furnace, boiler and superheater surfaces in addition to economizers and air heaters. Sootblowers will be spaced as specified by the boiler manufacturer to maintain unit efficiency and prevent coal ash pluggage. Ash deposits on the tubes may bridge the space between tubes unless stopped before such

pluggage occurs. Sootblowers are used to keep the tubes clean in order to maintain tube cleanliness and hence efficiency.

(1) Sootblowers may be either steam or air blowing.

(2) Unless water scarcity is an overriding factor, only steam should be used due to capital and operating costs of an air compressor and its related system. The cost of water treatment for the steam consumption by the sootblowers is an evaluation factor.

16.6 BOILER CASING OR SETTING. The boiler casing or setting is the most visible component of the unit and, if not properly designed, may be the source of excessive maintenance costs and loss of boiler efficiency.

(1) The term boiler setting was originally applied to the brick walls enclosing the furnace and heating surfaces of the boiler. Since the boiler settings and casing have been the source of a large portion of boiler related maintenance and operating (heat loss) costs, a great deal of attention and improvements have taken place. This is particularly true of the recent past during which time boilers became so large that heat losses and maintenance costs would have been totally unacceptable. As the technology of water treatment plus boiler design and manufacturing improved, water cooled furnace

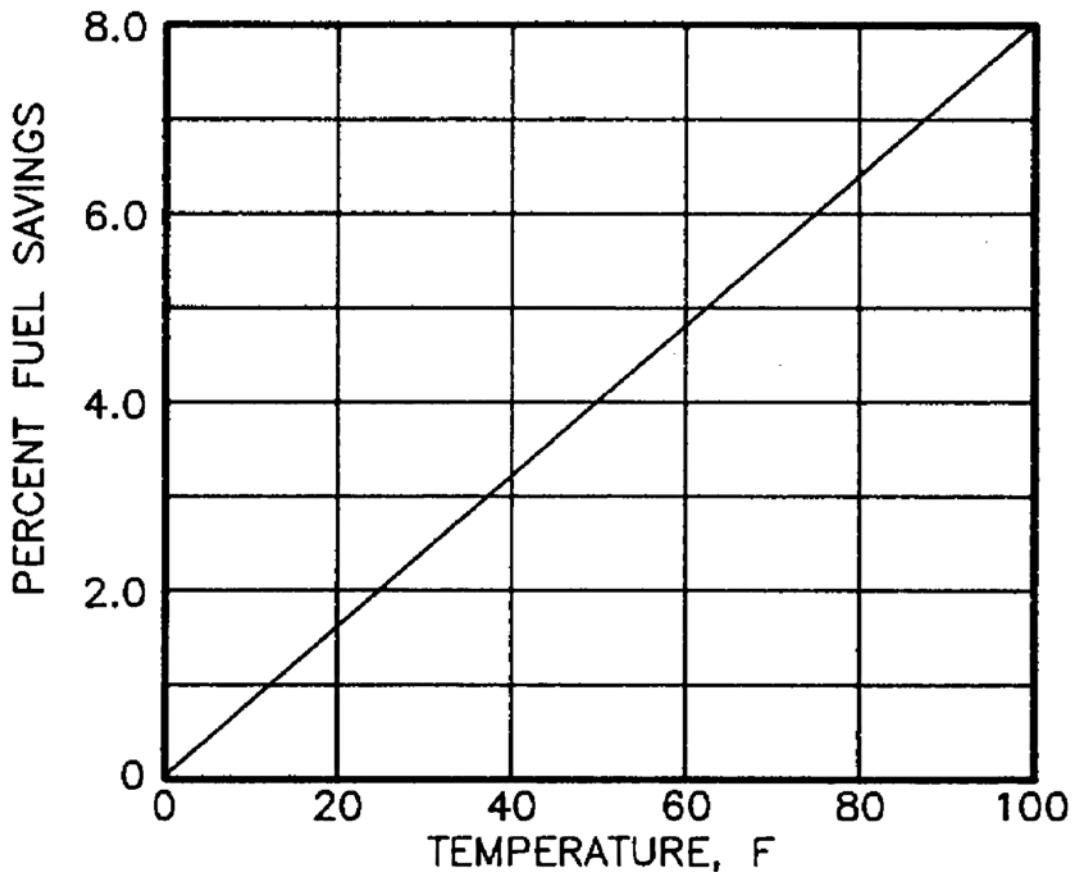

APPROXIMATE IMPROVEMENT IN BOILER UNIT EFFICIENCY AS FEEDWATER HEAT IS INCREASED.

Figure 15

Economizer fuel savings

surface replaced the refractory setting. Casing, frequently 10-gage, was used to seal the refractory placed adjacent to the furnace tubes and backed with block type insulation. This construction is still in use on some small boilers applicable to this publication. However; the products of combustion, particularly with coal fired boilers, will cause corrosion to take place and air leaks will develop when the corrosive substances (mainly sulfur) come in contact with the relatively cool casing. The first signs of leakage will be the gases condensing and dripping through the casing. This condition led the

manufacturers to place the casing behind the refractory and then insulating over the casing and protecting the insulation with galvanized or aluminum lagging. However, the latest and to date best design is the use of welded wall construction. Welded-wall construction positively contains internal flue gas pressure by seal welding metal plates between the tubes. Insulating materials cover the outside of the welded-wall tubes. Lagging is then placed over the insulation.

(2) The advantage of the welded wall construction currently being used by all major boiler manufacturers is that it virtually eliminates the flue gas corrosion that has taken place on the boiler casing. Another advantage is that it reduces air infiltration which in turn reduces exit gas temperature and fuel costs as well as the maintenance costs that were involved in repair of the refractory and insulation that previously existed. The design of boiler settings will include several considerations. High temperature air and corrosive gases will be safely contained. Air leakage will be held to a minimum. Heat loss is reduced to an acceptable level. Differential expansion of the component parts will be provided. The surface temperature should be such that it would not be a source of hazard or discomfort to operating personnel. If located outdoors, welded wall construction should be weatherproofed. The probability of injury or plant damage in the event of an explosion will be reduced. The use of welded wall construction and its inherent strength is probably the most imperative reason for the current design of boiler settings.

16.7 FLUE AND DUCTS. Flues and ducts will be designed to operate at the pressure and temperature to which they are subjected. As a general rule, the following velocities will be used in arriving at the cross-sectional flow area of boiler flues and ducts: cold air ducts - 2000 to 2500 fpm; hot air ducts - 3000 to 3500 fpm; gas flues upstream of particulate collection equipment - 2,500 to 3,000; gas flues - 3500 to 4000 fpm. It should be noted that velocities can be higher at elevated temperatures because the air or gas is less dense and therefore has less impact energy. Directional or straightening vanes should be used at bends in ductwork to minimize turbulence or draft loss.

16.8 DESUPERHEATERS. Normally on boilers with an outlet superheat temperature of no more than 750 degrees F, desuperheaters will not be used. However, if the steam is used for a process at a lower pressure and the temperature may be harmful or unwanted, a desuperheater can be installed in the steam line to control the desired temperature. Water for this device will normally be obtained from the boiler feed pump or a separate pump. The source of the water used by the desuperheater will be a deaerating heater and will be of the same quality as used in the boiler. If a desuperheater is used and the discharge of the device is into the superheater, the water and entrained impurities will be sprayed into the superheater tubes.

16.9 FAN BLADES AND APPLICATIONS. Table 7 provides a summary of available fan blade types and their respective applications. Items that must be identified for the design of a particular fan application include anticipated flow of air or combustion gas (pph), temperature of air or gas (degrees F), density of air or gas (pounds per cubic foot, lb/ft^3), fan inlet pressure (inches water gauge, in. wg), fan outlet pressure (in. wg), and fan curves of applicable fan types.

Fan blade type	Application
Backward inclined	HPA, CPA
Backward Curved	FD, ID, CPA, OFA, BF
Hollow Air Foil	FD, OFA, ID, BF
Radial	HPA, OFA, ID, FTB
Open Radial	Pulverizer Exhauster
Radial Tip	CPA, ID
FD - Forced Draft. ID - Induced Draft. HPA - Hot Primary Air. CPA - Cold Primary Air. OFA - Overfire Air. BF - Booster Fan. FTB - Fly Ash Transport.	

Table 7
Fan Blades and Applications.

16.10 FAN INLET. The following guidelines apply to the fan inlet design.

(1) Intake areas will be at least 20 percent greater than the fan wheel discharge areas.

(2) Fans positioned next to each other will be separated by at least six fan diameters and a separation baffle.

(3) Fans will have turning vanes or inlet boxes, or four to five diameters of straight duct at the inlet. The FD, PA, or Overfire Air (OFA) fan inlets located too close to building walls will have splitters.

(4) Where the duct arrangement imparts a swirl to the inlet of the air or gas, the swirl will be in the same direction as the fan rotation.

(5) All fans will use inlet bells to ensure a smooth air or gas flow at the fan inlet.

16.11 FAN OUTLET. For a minimum pressure drop, there will be three to six diameters of straight duct at the fan outlet.

17. BOILER WATER CIRCULATION AND CHEMICAL TREATMENT.

17.1 WATER CIRCULATION. A description of the internal or water/steam-circulation features of watertube boilers is listed below:

(1) The limits of the capability of a boiler is determined by water circulation and the feedwater and boiler water treatment. Boilers that do not circulate properly will rupture tubes in a very short period of time when operated at or near rated load. Such items as superheat and tube metal temperatures as well as fire side design considerations, physical limits of firing equipment, and air and gas fan and their physical limits should not being overlooked.

(2) The basic design of boilers and the size pressure and temperature ranges discussed in this manual are at the lower end of the technology scale.

(3) The American Boilers Manufacturers Association has set certain standards for boiler water limits. Table 8 shows the allowable concentrations for boiler water. These conditions are normally stated in proposals submitted by those manufacturers. They should be considered minimums for feedwater and boiler water treatment. All reputable feedwater treatment consultants or vendors will be able to meet and improve on the conditions required for the operating conditions of boilers covered by this publication.

Operating pressure, psig	Total solids, ppm	Total alkalinity, ppm	Suspended solids, ppm
0-300	3500	700	300
301-450	3000	600	250
451-600	2500	500	150
601-750	2000	400	100
751-900	1500	300	60
901-1000	1250	250	40

American Boiler Manufacturers Association, Stipulation in Standard Guarantees on Steam Purity

Table 8
Boiler water concentrations

(4) Boilers should not be operated at capacities or pressure and temperature conditions not anticipated by the manufacturer.

(5) As previously stated, boilers with superheaters are guaranteed to meet a 1 ppm steam purity condition leaving the steam drum. Boilers without superheaters can be guaranteed to meet a 3 ppm steam purity limit; or in the case of some low pressure, 150 psig saturated and lower, boilers used for heating or similar conditions may only be required to meet a 0.5 percent moisture condition. These limits are not stringent if the proper feedwater treatment is used and the proper equipment incorporated in the plant design. In addition, the operators must make proper use of the boiler water blowdown and the addition of the chemical treatment. Steam drum internals are revised when lower guarantee limits are stated. In fact at times, manufacturers may rely on natural separation of steam and water within the steam drum. In this case they may eliminate all steam drum internals except dry pipe or other such collecting device.

(6) In referring to the proper feedwater treatment and operation of the boiler blowdown and chemical treatment, attention to these items will pay off in the long run in reduced maintenance, retention of design efficiency and minimum cost of feedwater treatment chemicals through elimination of tube deposits and steam carryover problems.

(7) Figure 16 graphically describes the difference in the specific weights per cubic foot of water and saturated steam at various pressures up to approximately 3200 psig. This chart illustrates their ratio which may be considered a margin of safety. For boilers operating in the range of 150 to 400 psig, depending on the boiler design and the location of the tube in the furnace or boiler area as well as the slope and other similar conditions, the ratio of pounds of water circulated to the pounds of steam entrained and then released from the steam drum is approximately 15 to 1. This ratio decreases quite rapidly as the operating pressure rises. Circulation is assisted by the height of the boiler as well as the burner heat input located at the bottom of the U-tube which acts as a thermal pump.

17.2 CHEMICAL TREATMENT.

(1) Oxygen (O_2) is one of the more troublesome components of feedwater. It is readily removed by proper operation of the deaerating heater, together with a minimum water temperature of approximately 220 degrees F leaving that heater. Frequently a chemical O_2 scavenger, such as sodium sulfite or hydrazine, is used in the boiler feedwater

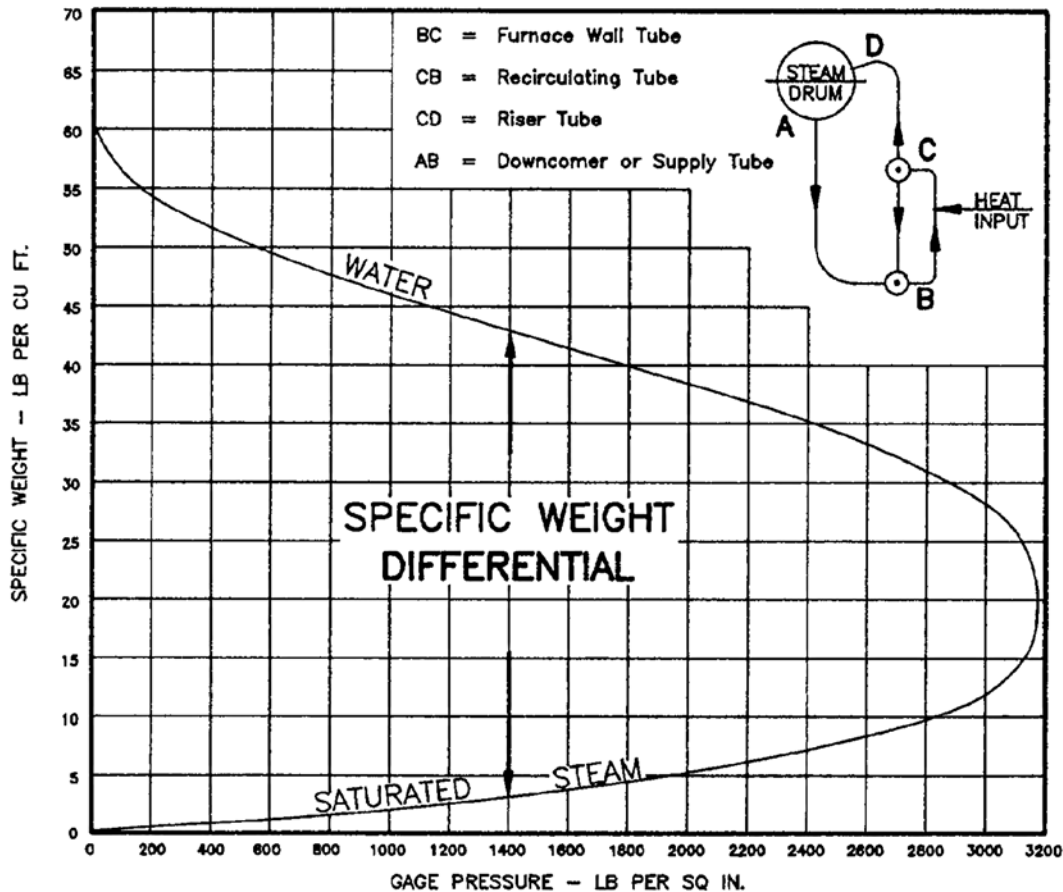

Figure 16

Specific weight differential of water to steam

to make sure any residual dissolved O₂ is not permitted to pit the tubes.

(2) Water hardness, expressed as calcium carbonate (CaCO₃) in ppm should be as close to zero as possible under all conditions. This can be accomplished by proper feedwater treatment and boiler water testing.

(3) Another item of importance is to maintain the proper acidity or alkalinity reading (pH value) of the boiler water. For boilers in the range of this publication, a pH reading of 9.0 to 10.5 should be acceptable depending on the chemical composition of the water source and the type of treatment used. In the latter category, some of the more common

types of treatment are sodium zeolite, hot lime zeolite, phosphate hydroxide and coordinated phosphate. In some cases the use of a demineralizer or evaporation may be desirable. These latter methods are more appropriate for higher pressures and temperatures in a steam cycle that has more complex problems due to the source of water for the boilers.

17.3 BOILER INTERNALS. Figures 17 and 18 indicate the steam drum internals showing the chemical feed line and the continuous blow pipe in addition to the feedwater line. The diameter and length of the drum are determined by the capacity of the boiler in the number of primary or cyclone separators needed. These devices, in addition to separating steam and water, aid water circulation by a reactive (pumping) action that promotes water flow along the length of the steam drum.

(1) The drying screen or secondary scrubbers further separate the steam and water particles so that the steam leaving the drum meets the desired steam purity condition. Another feature of the steam drum is the reserve water holding capacity which permits load swings besides being the collecting and distribution point of the steam.

(2) The primary function of the lower (mud) drum is to complete the circuit for the tubes in the boiler section and generally to act as a water reservoir and supply source for the lower furnace wall headers and tubes connected thereto. Except in unusual cases, the lower drum has no internals. It should be sized so that maintenance people can roll tubes into the drum holes as well as inspect those tubes. Some designs may permit rolling of

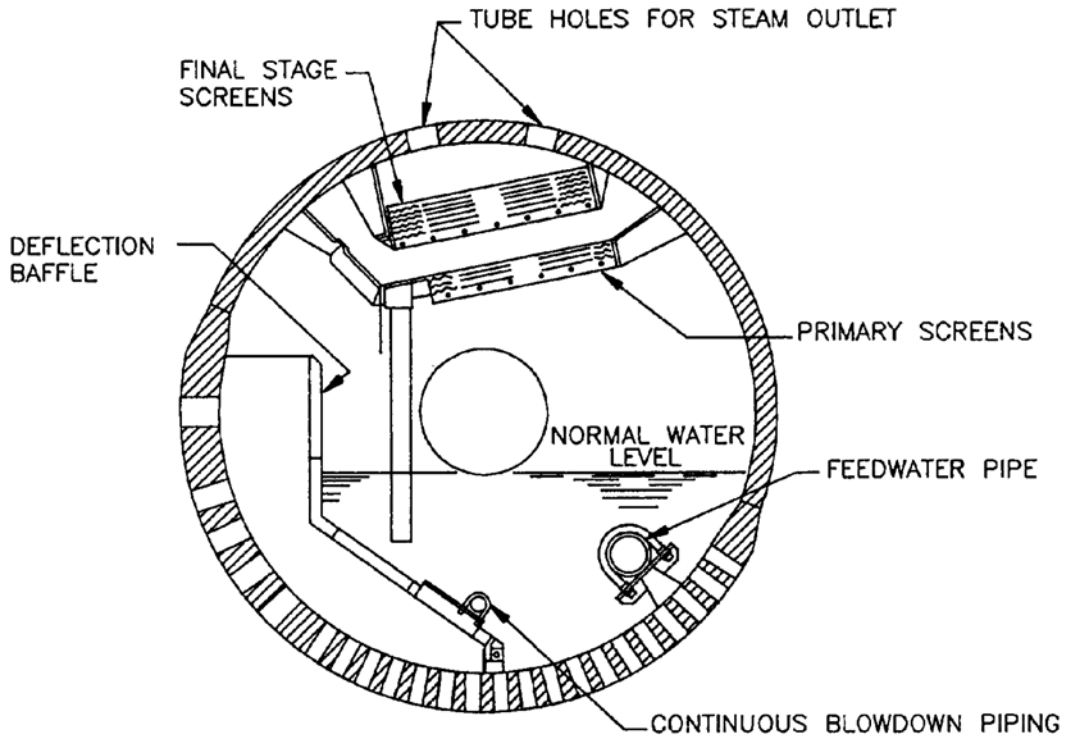

Figure 17
 Steam drum internals – baffle type

the tubes through inspection or handhole access ports.

(3) The amount of heating surface in the furnace and its configuration is generally arranged to suit the firing method, and to provide the necessary time and space for complete combustion of the fuel. Firing methods include gas, oil, pulverized coal, stoker fired, and atmospheric circulating fluidized bed. The particular fuel(s) fired also impact design. The boiler bank is sized in conjunction with the furnace and superheater to provide the steam capacity as well as to lower the exit gas temperature to the value required. The economizer, if provided, is sized to lower the exit gas temperature to the desired value without getting into a (steaming) condition under normal operating conditions. Generally this means the economizer is sized to permit a 25 to 50 degrees F margin between the exit water temperature and saturation temperature at operating

conditions. The air heater, if provided, is sized to provide the desired air temperature to the pulverizers or stoker as well as to lower the exit gas temperature to the desired value.

(4) Fitting the size of each component into the most efficient and least expensive unit is the function of the boiler manufacturer and their engineering staff. In addition to the various mathematical approaches for sizing these components, a good deal of this design is based on years of experience with its empirical data as well as various manufacturing considerations.

18. BOILER STACKS.

18.1 GENERAL. In boiler operation applications, the stack flue gas temperature will be below the dew point a considerable amount of the time due to low loads, start-up and shutdown, plus normal weather conditions. Drainage of water should be provided due to operating conditions as well as rain and snow. Some of the factors to consider in stack design are:

- (1) Flue gas conditions. The erosive and corrosive constituents, dew point temperature, and maximum temperature, if bypassing the economizer or air preheater.
- (2) Temperature restrictions which relate to the methods of construction and the type of stack lining material to be utilized.
- (3) Stack and lining material must be selected to withstand corrosive gases (related to sulfur in the fuel).
- (4) Wind, earthquake and dead loads, which include the moment load from deflection.

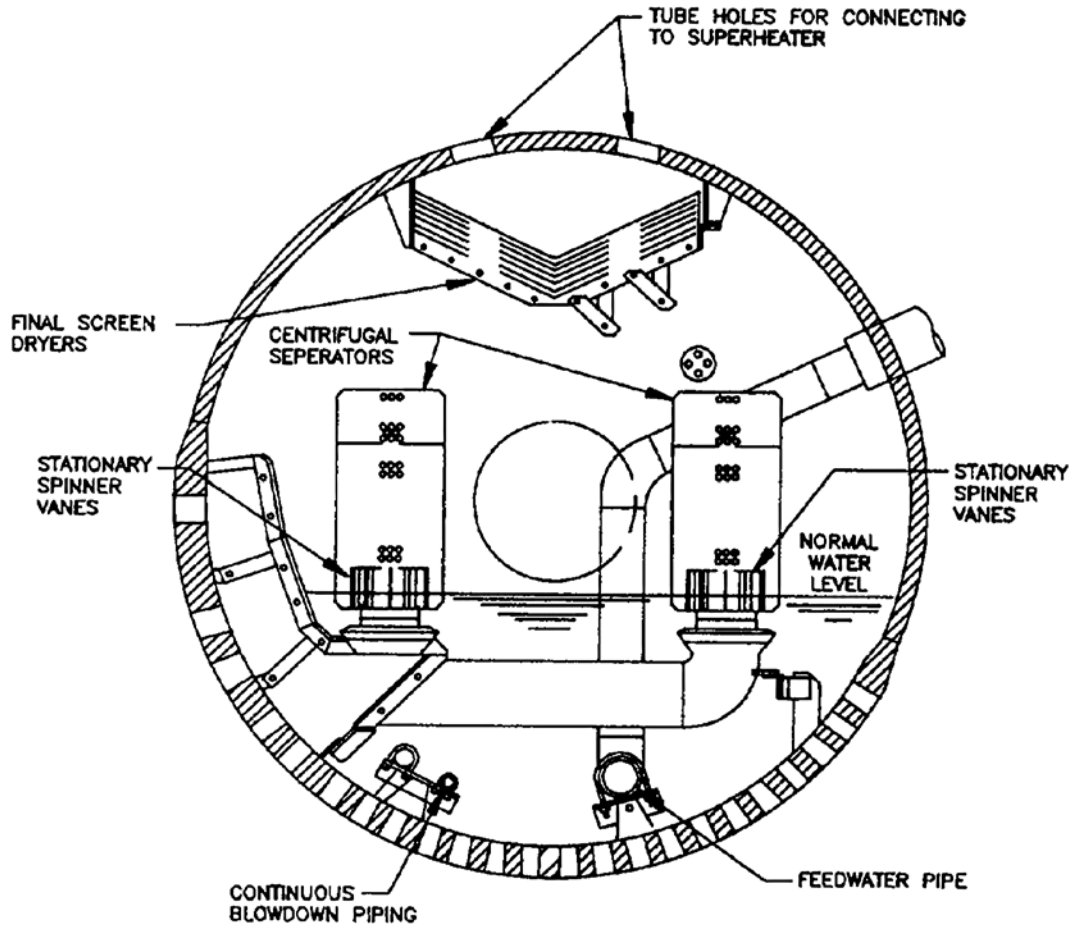

Figure 18

Steam drum internals – perforated centrifugal type

(5) After structural adequacy has been determined, both static and dynamic analyses should be made of the loads.

(6) With welded steel stacks, a steady wind can produce large deflections due to Karmen Vortices phenomenon. If the frequency of these pulsations is near the stack's natural frequency, severe deflections can result due to resonance.

(7) The plant location, adjacent structures, and terrain will all affect the stack design.

(8) Cleanout doors, ladders, painter trolleys, EPA flue gas testing ports and platforms, lightning protection and aviation warning lights will be provided, as required.

18.2 STACK DESIGN. The stack height calculations are for the effective stack height rather than the actual height; this is the distance from the top of the stack to the centerline of the opening of the stack where the flue gas enters. Air and gas flow losses through the inlet air duct, air heater (air side), windbox, furnace and passes, air heater (gas side) or economizer, gas cleanup equipment and other losses through duct and breeching should be plotted and overcome with the fans. The kinetic discharge head, the friction losses at the entrance to the stack, and friction losses in the stack should be provided by the natural draft of the stack. Barometric pressures adjusted for altitude and temperature must be considered in determining air pressure. The following stack parameters must be determined:

(1) The extreme and average temperatures of ambient air and gas entering the stack.

(2) All heat losses in the stack (to find mean stack temperature).

(3) Altitude and barometric corrections for specific volume.

(4) Gas weight to be handled. The infiltration of air and combustion air into the stack casing and ductwork must also be considered.

(5) Stack draft losses due to fluid friction in the stack and kinetic energy of gases leaving the stack.

(6) The most economical stack diameter and the minimum stack height to satisfy dispersion requirements of gas emissions.

(7) The stack height for required draft. (Where scrubbers are used, the temperature may be too low for sufficient buoyancy to overcome the stacks internal pressure losses.)

(8) A static and dynamic structural analyses must be made of the wind, earthquake, dead, and thermal loads. Vortex shedding of wind loads must be considered to be assured that destructive natural frequency harmonics are not built into the stack.

18.3 STACK CONSTRUCTION. The stack height and diameter, support, corrosion resistance, and economic factors dictate the type of construction to be utilized.

(1) Stacks are generally made of concrete or steel because of the high cost of radial brick construction. If stack gases are positively pressurized, or if flue gases will be at or below the dew point of the gases, corrosion resistant linings must be provided; linings must be able to withstand temperature excursions which may be experienced in the flue gas, if flue gas scrubbers are bypassed.

(2) Stacks of steel or concrete construction will be insulated to avoid condensation by not allowing the internal surfaces to drop below 250 degrees F. This requirement does not apply when scrubbers are used with low temperature discharge (150 to 180 degrees F) into the stack because the flue gas is already below the dew point temperature.

(3) A truncated cone at the top of the stack will decrease cold air downdrafts at the periphery of the stack and will thus help maintain stack temperature, but stack draft will decrease considerably.

19. ADJUSTABLE SPEED DRIVES. Significant electrical power savings can be realized at reduced boiler loads by installing adjustable speed drives (ASD) on ID and FD fans. The economics of ASDs depend on the boiler load profile (number of hours at different loads). The feasibility of ASD installation should be verified by an LCCA.